

---

# CONTENTS

---

---

# T19C BEV Disassembly Manual

---

# Section 1 Introduction

CONTENTS	Page
Overview.....	3
Introduction to Relevant Laws and Regulations .....	4
Term Explanation .....	5
General Description .....	7
Disassembly Site and Equipment .....	8
Safety Warning Description.....	16

# Overview

## Overview Content

The compilation of the "Disassembly Manual" aims to ensure the environmentally friendly disposal of end-of-life vehicles, assist and guide recycling and disassembly enterprises to efficiently and safely complete disassembly operations, handle waste in a scientific and environmentally friendly manner, enhance the environmental protection standards and recycling capabilities of end-of-life vehicle recycling and disassembly enterprises, while simultaneously increasing the recycling rate of end-of-life vehicles and reducing the potential for harm to the environment and personnel during the disassembly process.

Dear user, this disassembly manual is applicable to the T19C BEV. The images and instructions with specified models in this manual are only valid for this vehicle model. Therefore, please make sure to confirm the vehicle model by referring to the model number in the table before proceeding with the disassembly.

### Detailed Information of Vehicle Model

Generic Name	OMODA E5
English Name of Vehicle Model	OMODA E5
Year of Launch	2024
Applicable Model	T19C BEV
Length/Width/Height (mm)	4400/1830/1588
Wheel Base (mm)	2630
Luggage Compartment Capacity (L)	350
Tire Size	225/60 R18, 225/55 R19, 225/65 R17, 215/60 R17
Curb Weight (kg)	1432
Fuel Type	Electric
Drive Mode	Front Wheel Drive

---

# Introduction to Relevant Laws and Regulations

## EU RRR Relevant Directive Requirements

### EU Directive 2000/53/EC on End-of-Life Vehicles

Requirements for reuse, recycling and recovery under Article 7 of the End-of-Life Vehicles Directive by the European Parliament and the Council of the European Union:

- Before January 1, 2006, the average reuse and recovery rate of all end-of-life vehicles should be at least 85%. During the same period, the average reuse and recycling rate should be at least 80%. For vehicles produced before January 1, 1980, the average reuse and recycling rate must not be less than 75%; the average reuse and recovery rate must not be less than 70%.
- Before January 1, 2015, the average reuse and recycling rate of all end-of-life vehicles should be at least 95%; during the same period, the average reuse and recovery rate should be at least 85%.

### EU 2005/64/EC Directive Requirements

According to Annex I of the amended Directive 70/156/EEC of the European Parliament and the Council regarding the reusability, recyclability and recoverability of automobiles, M1 class vehicles shall meet the following requirements:

- The weight of reuse and/or recycling must account for at least 85% of the total vehicle weight;
- The weight of recovery must account for at least 95% of the total vehicle weight.

The European Union has banned or restricted the use of lead, mercury, cadmium, or hexavalent chromium in automotive materials or components placed on the market after July 1, 2003, with certain exemptions allowed. Directive 2011/37/EU (Annex II of Directive 2000/53/EC) lists the vehicle materials or components exempted from Article 4(2)(a) of Directive 2000/53/EC. Materials or components containing lead, mercury, cadmium, or hexavalent chromium are allowed in vehicles placed on the market before the exemption dates.

---

## Term Explanation

### 1. End of Life Vehicles (ELVs)

Vehicles that have met the criteria for mandatory scrapping as stipulated by national standards or are no longer in use (or are requested to be discarded) by their owners.

### 2. Dismantling Information

Guidance information provided by manufacturers for the proper and environmentally friendly disposal of end-of-life vehicles.

### 3. Removal

The process and manner for end-of-life vehicles involve conducting non-hazardous disposal, disassembly reusable components and major assemblies; separating and storing items based on their material types; and flattening or cutting the vehicle body and structural parts.

### 4. Disassembly/Dismantling

The process of disassembly vehicles, assemblies, components, or other parts.

### 5. Reuse

Any use of end-of-life vehicle parts for their intended design purpose.

### 6. Recycling

Through reprocessing of waste materials, they can be made to meet their original usage requirements or be used for other purposes, excluding processes that generate energy from them.

### 7. Recovery

Through reprocessing of waste materials, they can be made to meet their original usage requirements or be used for other purposes, including processes that generate energy from them.

### 8. Prohibited Substances

Substances that pose a hazard or potential risk to human health, animal and plant life safety, and the environment, and are present in automotive products within a certain concentration limit.

### 9. Vehicle Materials

The collective term for various materials that constitute vehicle products and components, including metallic materials, non-metallic materials, and composite materials. Based on their usage, they are divided into manufacturing materials and operational materials. Manufacturing materials are the various materials that constitute vehicles and components, while operational materials refer to the materials consumed during the use of vehicles.

### 10. Pretreatment

During the disassembly of end-of-life vehicles, the first step is to handle and collect toxic and hazardous components or materials that are prone to causing environmental pollution or personal injury. It mainly includes the following vehicle components and/or materials:

All liquids (including fuel, engine lubricating oil, transmission/gearbox (including rear differential and/or transfer case) oil, power steering oil, coolant, brake fluid, shock absorber fluid, air conditioning

---

---

refrigerant, windshield washer fluid, and hydraulic suspension fluid, etc.), airbags, batteries, oil filters, liquefied petroleum gas (LPG) tanks, compressed natural gas (CNG) tanks, tires, catalytic converters, etc.

---

## General Description

### Disassembly Requirements

Disassembly must comply with the corresponding national laws and regulations, in accordance with environmental, health, and worker protection regulations, which cover all tasks, including handling, sorting, transportation, storage, and other methods for the disposal of parts, chemicals, filters, and other materials. Disassembly should prioritize the protection of land and surface water resources to avoid contamination. Hazardous and toxic substances should be handled in well-ventilated areas in accordance with the requirements of the corresponding laws and regulations. Staff must be familiar with and respect the corresponding safety instructions. Hazardous waste materials after disassembly should be transported to locally approved waste disposal sites. According to the corresponding standards and requirements, all working fluids and specified parts and assemblies must be removed first. Relevant large parts/assemblies must be easily removable, and all working fluids should be fully extracted as much as possible;

**Remove the following parts before disassembling the vehicle**

- Separate the battery;
- Separate or neutralize components with potential explosion hazards, such as airbags and seat belt pretensioners;
- Separate all components and those verified to contain mercury;
- Separate metal components containing copper, aluminum, and magnesium before they are separated by scrap car shredders;
- Separate tires and large plastic components (such as shock absorbers, instrument panels, liquid containers, etc.) before they are separated by scrap car shredders, as they can be directly converted into raw materials for recycling;
- Separate the glass

### Extract Liquids

- Separate and store coolant, antifreeze, brake fluid, air conditioning refrigerant, and other liquids contained in end-of-life vehicles. These liquids must be stored separately for reuse.

**Dismantle other components as required.**

---

---

# Disassembly Site and Equipment

## Disassembly Site

- The operating area should be no less than 10,000m<sup>2</sup>, with the working area (including storage and disassembly sites) covering no less than 6,000m<sup>2</sup>
- The ground of the end-of-life vehicle storage area (including temporary storage) should be hardened and impermeable
- The disassembly site should be an enclosed or semi-enclosed workshop with a floor that prevents leakage. The disassembly workshop should be well-ventilated and well-lit, with complete safety prevention facilities, and located far away from residential areas
- A warehouse for used parts should be set up
- The main drainage outlets of the storage area and disassembly workshop should be equipped with oil-water separators and connected to drainage ditches

## Facilities and Equipment

- Equipped with vehicle weighing equipment.
- Equipped with an indoor disassembly pretreatment platform, along with dedicated waste liquid collection devices and specialized, sealed containers for the classified storage of various waste liquids.
- Equipped with a refrigerant collection device for automotive air conditioning.
- Equipped with containers for the classified storage of capacitors and batteries containing polychlorinated biphenyls or polychlorinated terphenyls.
- Equipped with frame cutting equipment, body shortening or flattening equipment.
- Equipped with lifting and transportation equipment.
- Equipped with an assembly disassembly platform or a detailed disassembly platform.
- There should be no less than 5 professional technicians, whose professional skills should meet the corresponding requirements for standardized disassembly, environmental protection operations, and safe operations (including the collection, storage, and transportation of hazardous substances). Operators in relevant positions should comply with national regulations requiring certification for employment and hold the necessary licenses if stipulated by law.
- Equipped with office facilities such as computers.
- Equipped with fire-fighting facilities that comply with relevant national regulations.

Detailed example photos of disassembly equipment are provided in the images. Enterprises may appropriately add equipment and tools that are not listed according to their own needs.

---

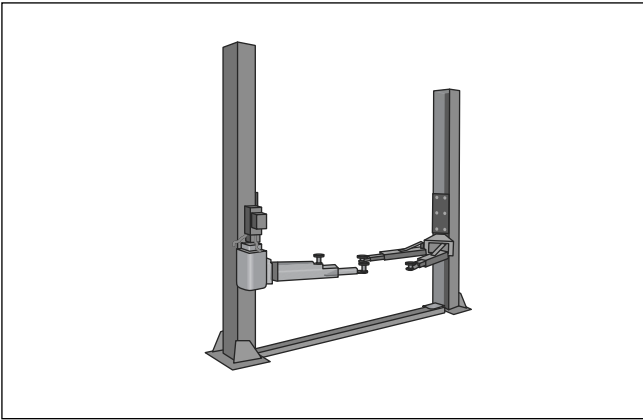

Lift

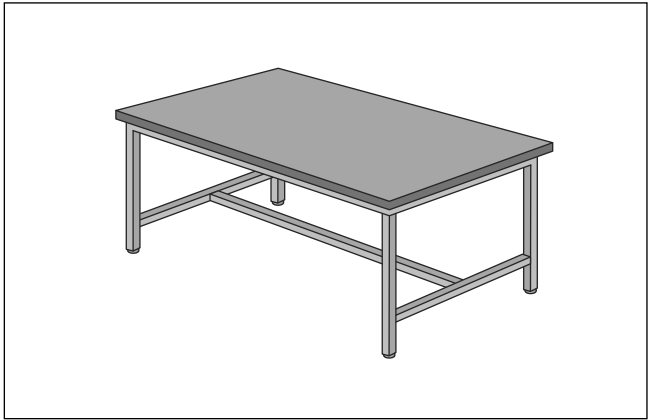

Workbench

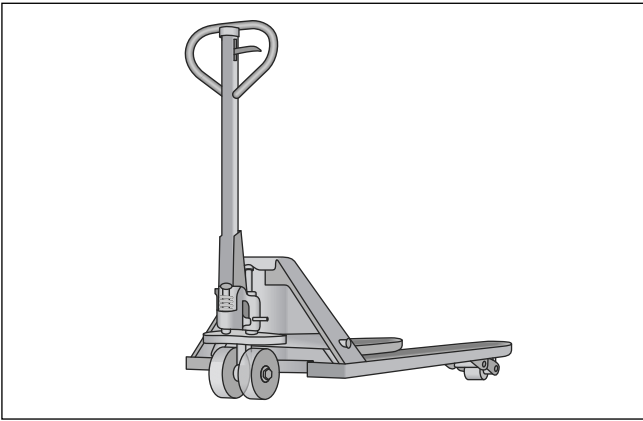

Hydraulic Forklift

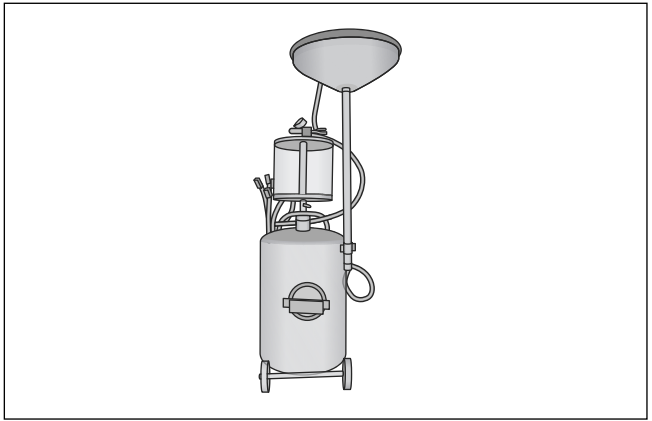

Pneumatic Oil Suction Machine

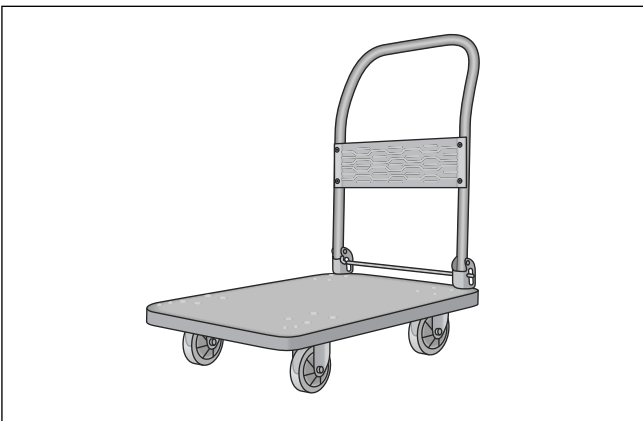

Trolley

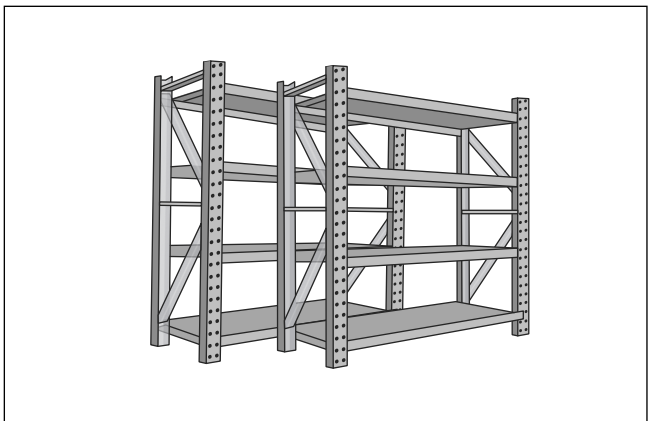

Storage Shelf

## Vehicle Disassembly Tool

### General Disassembly Tool

- Open-end wrench – Can be used for standard bolts and nuts.
- TORX wrench – Suitable for assembling and disassembling bolts and nuts in confined spaces. It can be used for standard bolts and nuts, especially when a larger torque is required for assembling or disassembling, making it the preferred choice for such tasks.
- Socket wrench – Can be used for standard bolts and nuts. It is appropriate for assembling and disassembling bolts and nuts in both general locations and those in deep, recessed, or concealed narrow spaces. When paired with extension bars, it can speed up the process.
- Torque wrench – Generally used for assembling and disassembling bolts and nuts that require a specific tightening torque, such as those on cylinder heads, crankshaft main bearing caps, and connecting rod caps.
- Adjustable wrench – Generally used for assembling and disassembling bolts and nuts of different sizes.
- Pipe wrench – Used for turning metal pipe fittings or other cylindrical workpieces.
- Screwdriver (flat tip and cross tip) – Used for assembling and disassembling screws.
- Saw – Used for cutting metal wires, bending small parts and plastics, etc.
- Crowbar – Used to avoid direct contact between the hammer and the vehicle body, protecting the vehicle body from damage during assembly and disassembly.
- Puller – Used for removing tightly fitted components such as bearings and gears.

Example photos of general disassembly tools are provided in the illustration

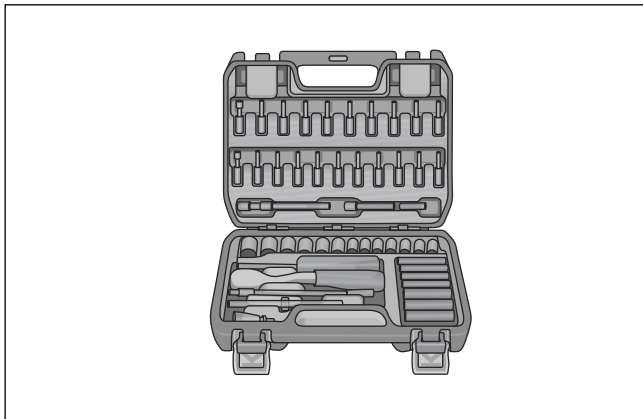

45-Piece Vehicle Disassembly Tool Set

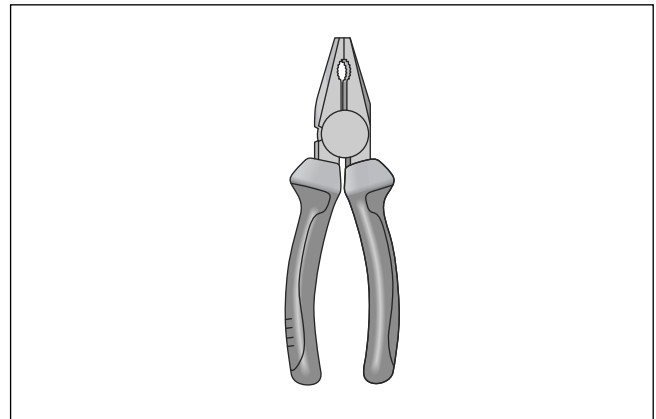

Vise

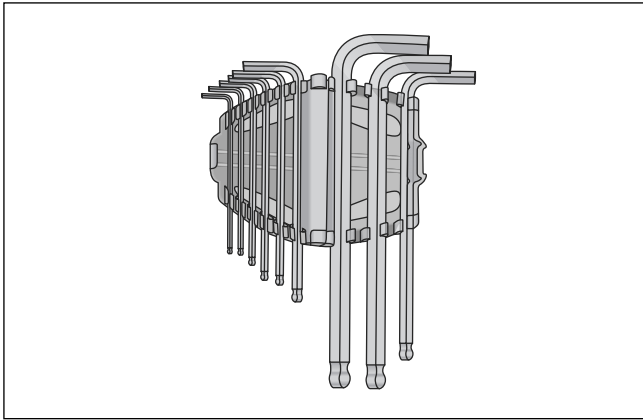

Inner Hexagon Set

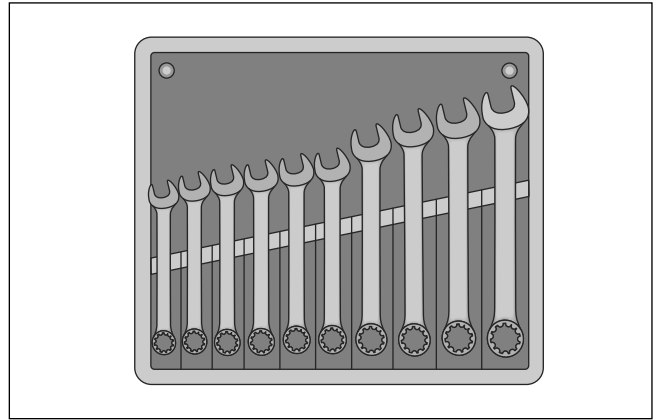

10-Piece Open-End Wrench Set

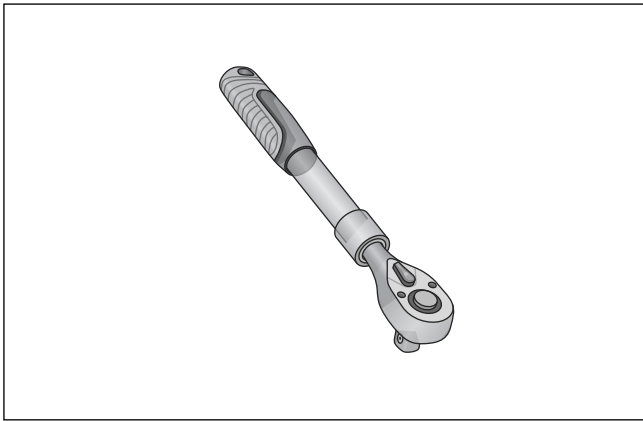

Ratchet Wrench

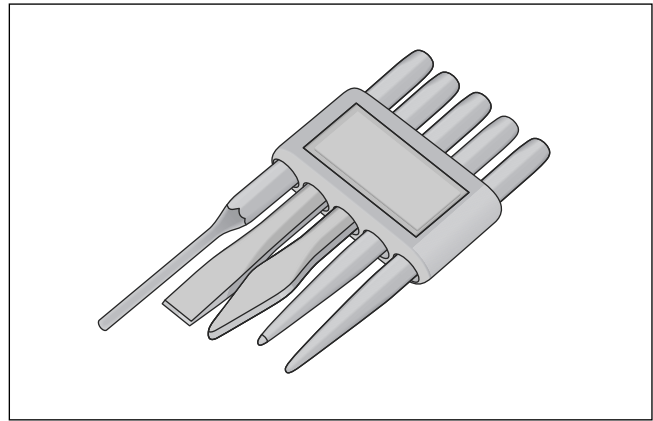

5-Piece Chisel and Punch Set

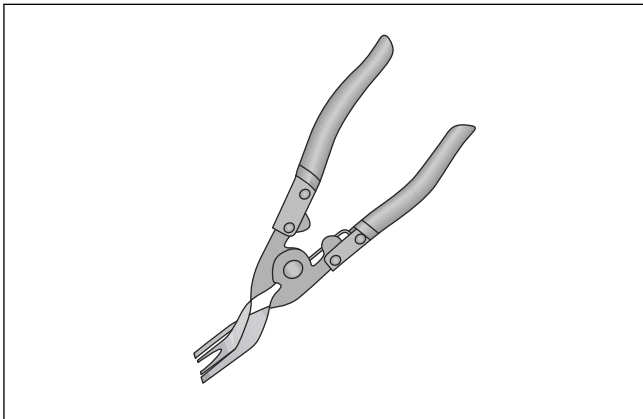

Special Pliers for Removing Plastic Rivets

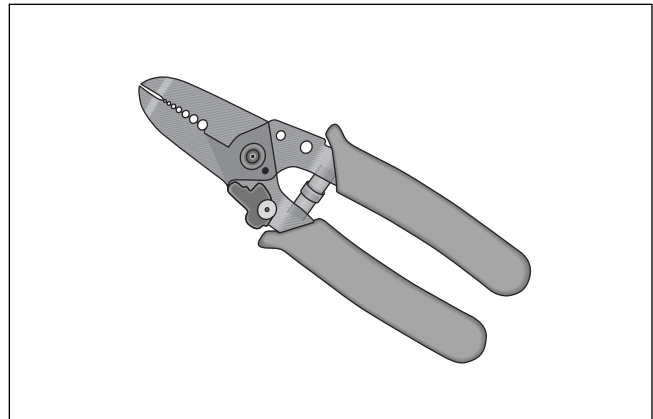

Wire Stripper

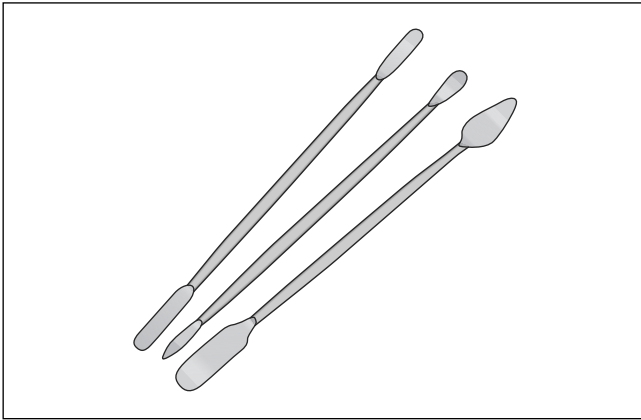

Crowbar Combination

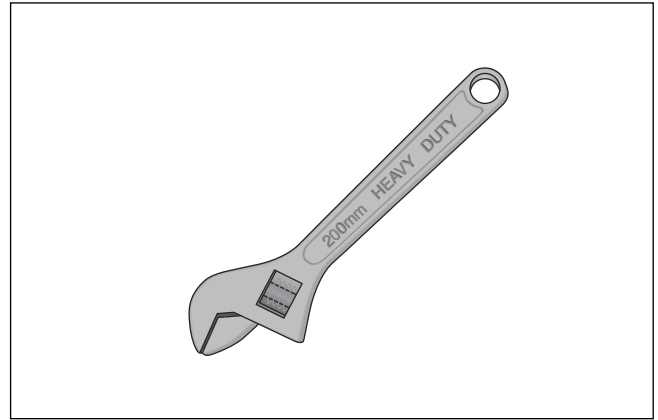

Adjustable Wrench

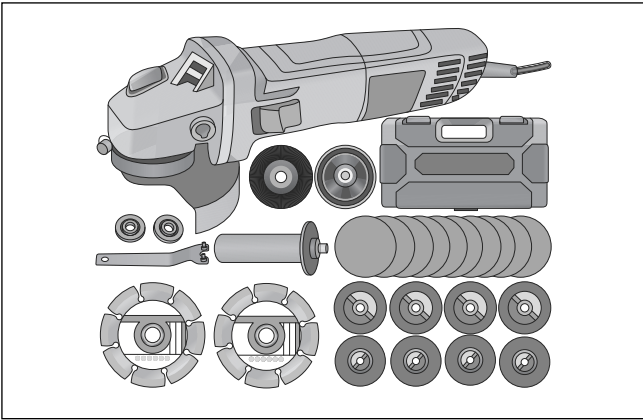

Cutting Machine

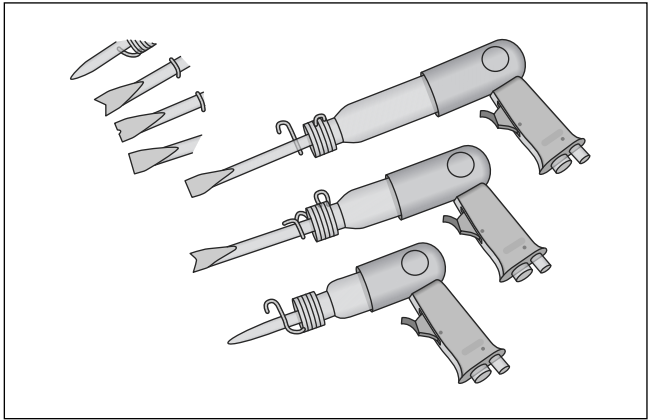

Pneumatic Gun

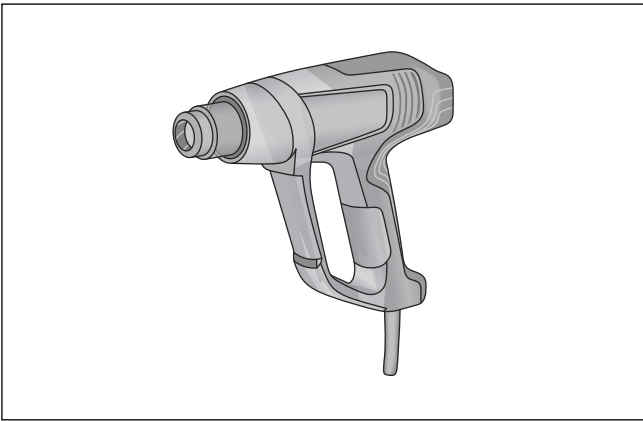

Electric Gun

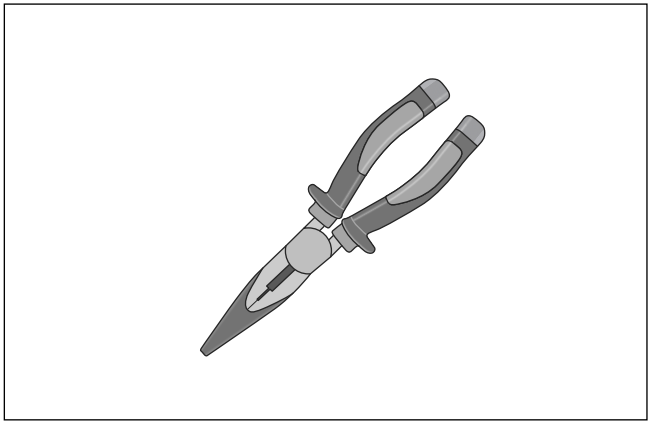

Needle Nose Pliers



Screwdriver Set

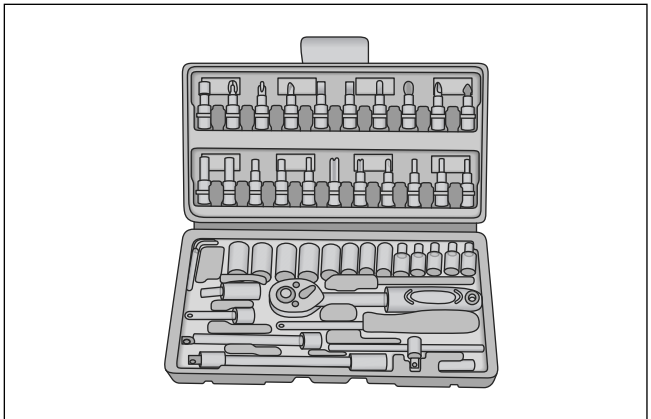

18-Piece Socket Set

Example photos of protective equipment and some specialized tools are provided in the illustration

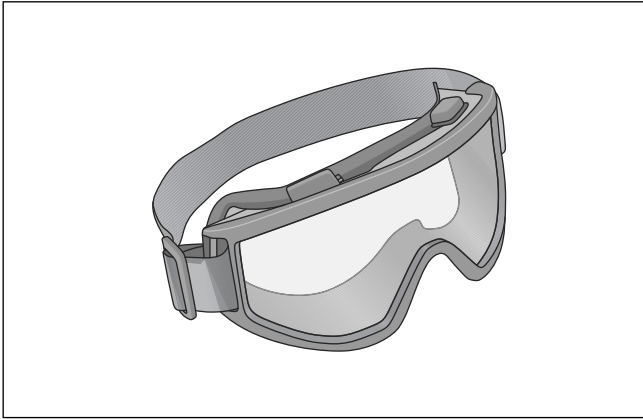

Protective Goggles

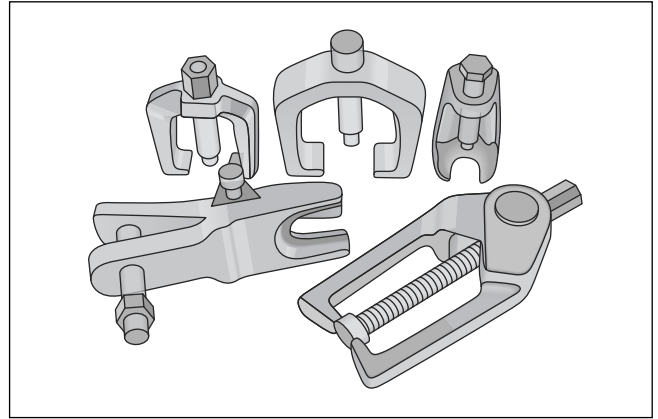

Ball Joint Puller

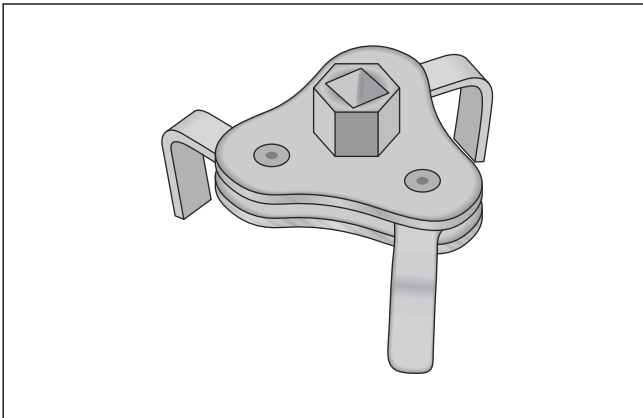

Dual-purpose Filter Wrench

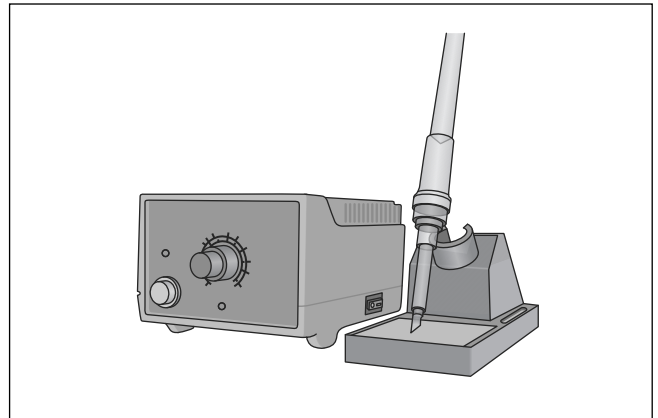

Electric Soldering Iron

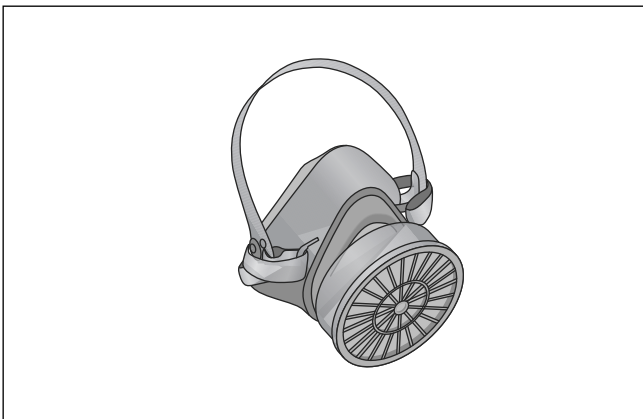





Gas Mask





## Technical Requirements for Disassembly

- Directly detonate the airbag or detonate after removing safety components
  - Use special tools and containers to empty and collect waste liquid in the vehicle
  - Use special equipment to recover the refrigerant of automobile air conditioning, with different refrigerants being recovered separately
  - When disassembling end-of-life automotive parts, appropriate special tools should be used to ensure the reusability of the parts and the recyclability of materials as much as possible
  - Reusable parts that have been removed should be stored indoors
  - Containers for storing various parts, materials, and waste should be labeled to avoid mixing and commingling
  - Solid waste should be handed over to waste disposal units that meet relevant national standards for processing, and must not be incinerated or discarded
-

## Safety Warning Description

### Safety Warning Sign Description Icon

Sign Type	Sign	Text Description
Warning Sign		This symbol indicates that the part/assembly is explosive.
		This symbol indicates that the part/assembly is a toxic and hazardous chemical.
		This symbol indicates that the part/assembly is flammable.
		This symbol indicates that the part/assembly is corrosive.
		This symbol indicates that the part/assembly is a high-voltage item.

Instruc- tion Sign		This icon indicates that a protective helmet must be worn during disassembly.
		This icon indicates that protective goggles must be worn during disassembly.
		This icon indicates that ear protectors must be worn during disassembly.
		This icon indicates that protective gloves must be worn during disassembly.
		This icon indicates that protective footwear must be worn during disassembly.

## Section 2 Vehicle Disassembly Instructions

CONTENTS	Page
Detailed Process and Instructions.....	19

## Detailed Process and Instructions

### 2.1 Pretreatment

#### 2.1.1 Driver Airbag Assembly

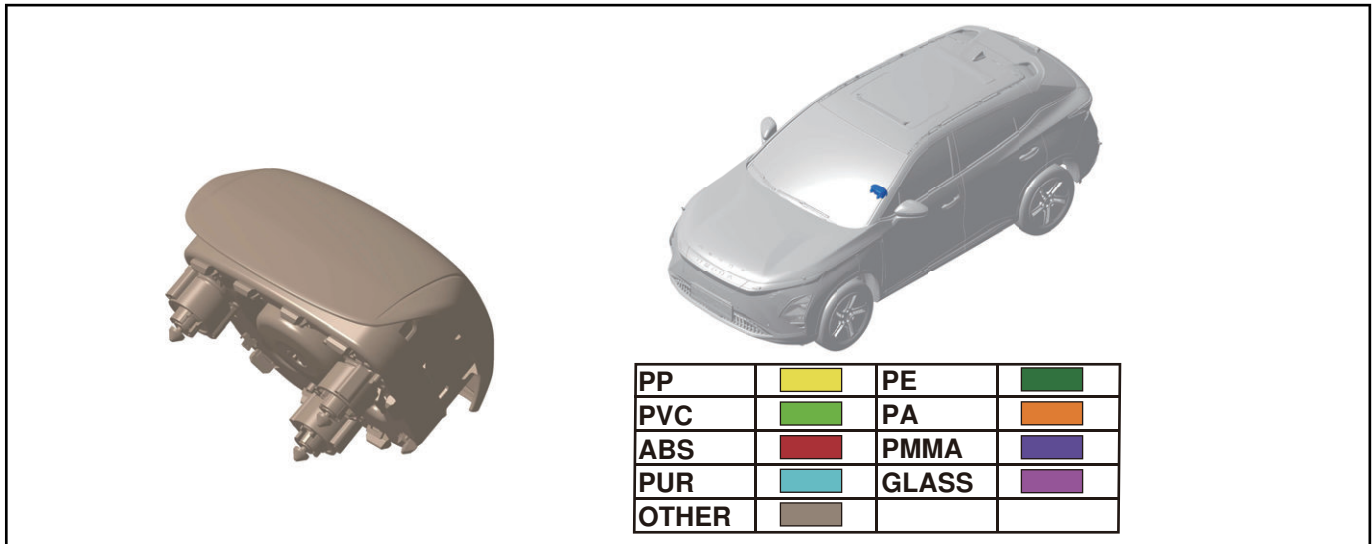

Driver airbag assembly:

Applicable Model	T19C EV
Position Description	Center of steering wheel
Quantity	1
Weight (Kg)	1.03
Main Material	DC01, PA66, TPO
Fastener	Clip
Number of Fasteners	3
Disassembly Tool	Flat tip screwdriver
Disassembly Method	Loosen the fasteners for disassembly
Recycling Pathways	The deployed airbag can be crushed, sorted, and reused.
Precautions for Disassembly	Wear protective equipment (goggles, gloves, etc.)

Safety warning sign:



## 2.1.2 Front Passenger Airbag Assembly

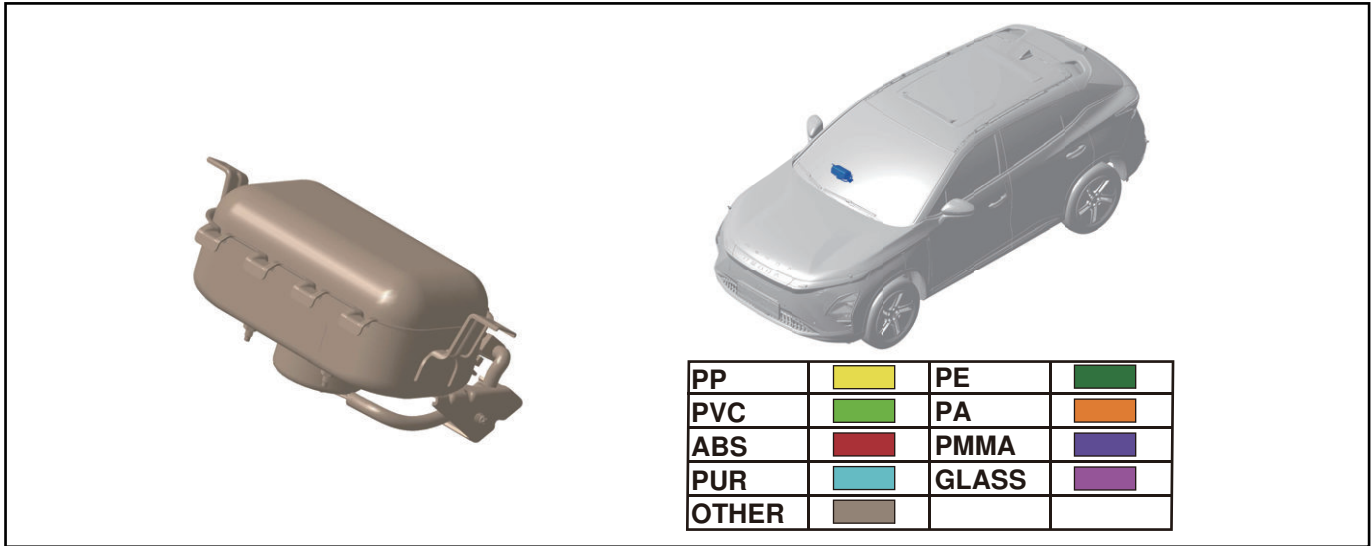

Front passenger airbag assembly:

Applicable Model	T19C EV
Position Description	On the instrument panel crossmember
Quantity	1
Weight (Kg)	1.44
Main Material	DC01, PA66
Fastener	Screw, clip
Number of Fasteners	9
Disassembly Tool	Socket wrench
Disassembly Method	Loosen the fasteners for disassembly
Recycling Pathways	The deployed airbag can be crushed, sorted, and reused.
Precautions for Disassembly	Wear protective equipment (goggles, gloves, etc.)

Safety warning sign:



### 2.1.3 Left Curtain Shield Airbag Assembly

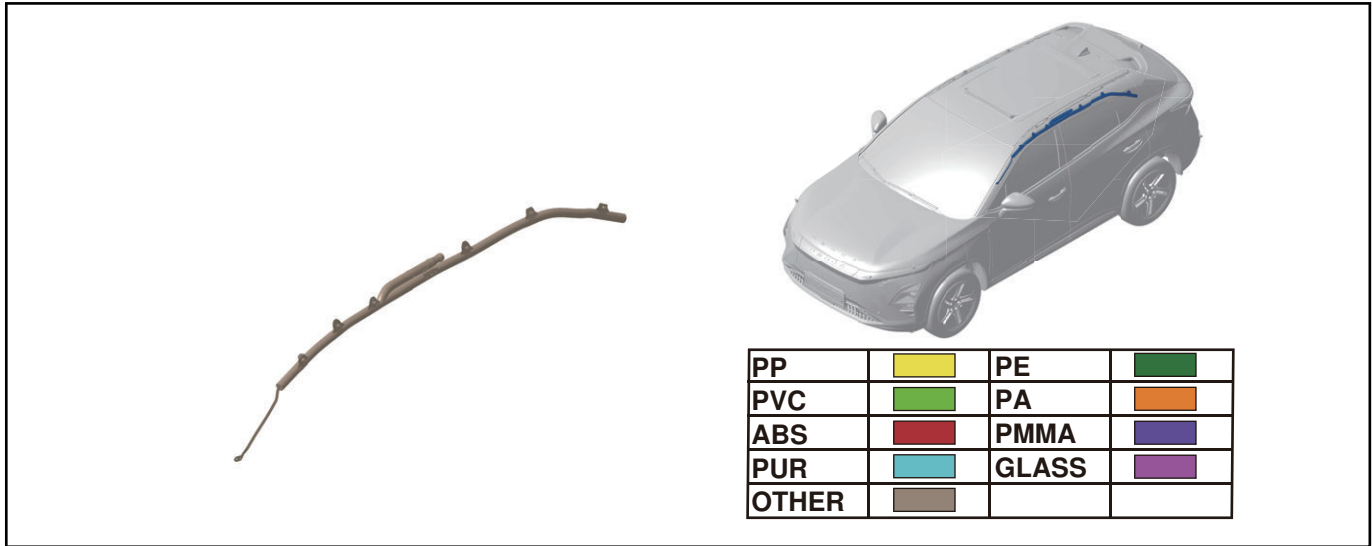

Left curtain shield airbag assembly:

Applicable Model	T19C EV
Position Description	Position near the roof on quarter
Quantity	1
Weight (Kg)	1.26
Main Material	Fabrics, PET
Fastener	Bolt
Number of Fasteners	4
Disassembly Tool	Socket wrench
Disassembly Method	Loosen the fasteners for disassembly
Recycling Pathways	The deployed airbag can be crushed, sorted, and reused.
Precautions for Disassembly	Wear protective equipment (goggles, gloves, etc.)

Safety warning sign:

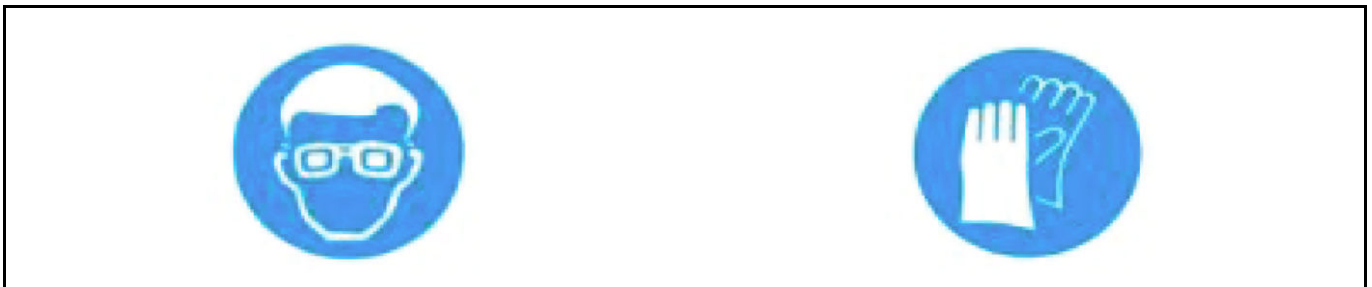

### 2.1.4 Right Curtain Shield Airbag Assembly

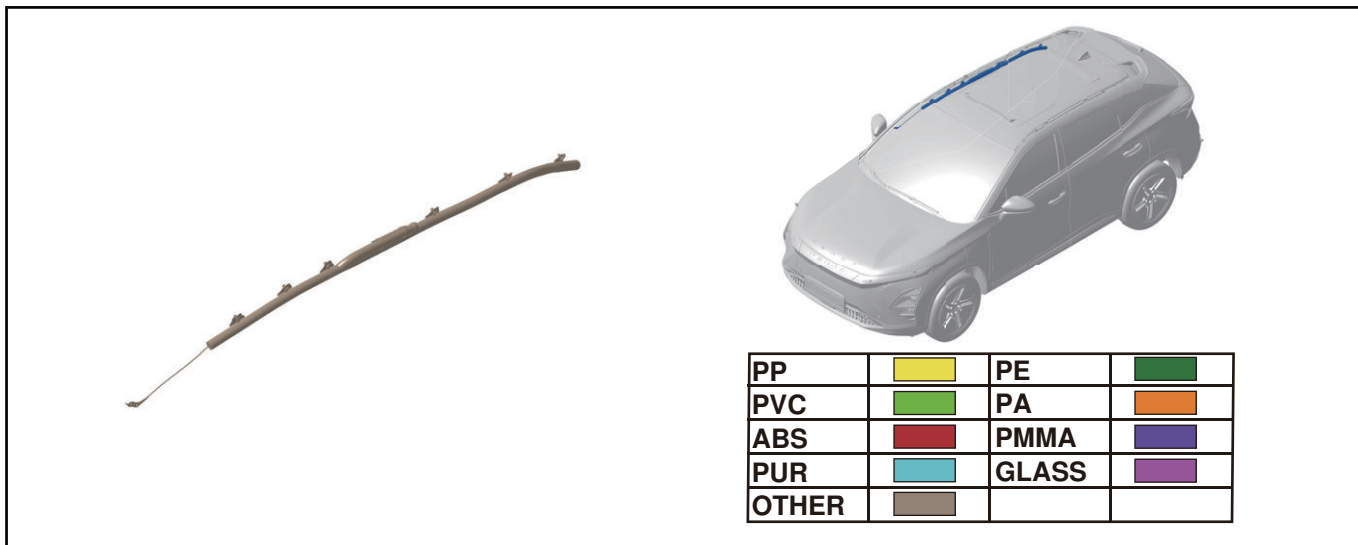

Right curtain shield airbag assembly:

Applicable Model	T19C EV
Position Description	Position near the roof on quarter
Quantity	1
Weight (Kg)	1.26
Main Material	Fabrics, PET
Fastener	Bolt
Number of Fasteners	4
Disassembly Tool	Socket wrench
Disassembly Method	Loosen the fasteners for disassembly
Recycling Pathways	The deployed airbag can be crushed, sorted, and reused.
Precautions for Disassembly	Wear protective equipment (goggles, gloves, etc.)

Safety warning sign:



## 2.1.5 Front Left Airbag Assembly

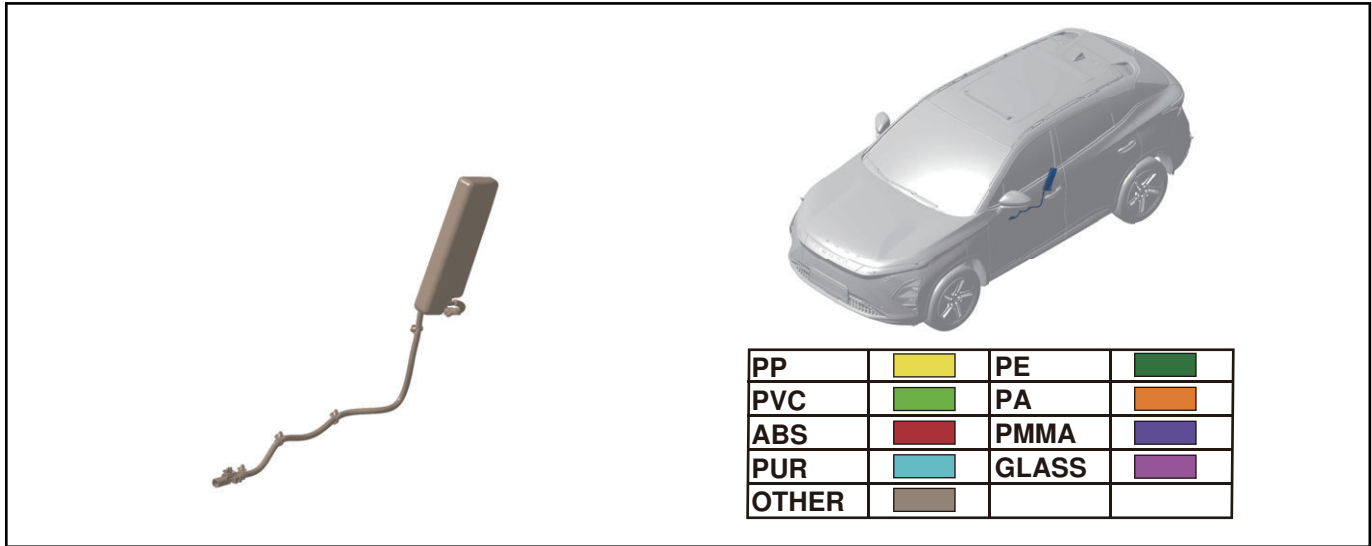

Front left airbag assembly:

Applicable Model	T19C EV
Position Description	Side of front left seat
Quantity	1
Weight (Kg)	0.4
Main Material	PA66, SAE 1510M HY-03-186
Fastener	Bolt
Number of Fasteners	2
Disassembly Tool	Socket wrench
Disassembly Method	Loosen the fasteners for disassembly
Recycling Pathways	The deployed airbag can be crushed, sorted, and reused.
Precautions for Disassembly	Wear protective equipment (goggles, gloves, etc.)

Safety warning sign:



## 2.1.6 Front Right Airbag Assembly

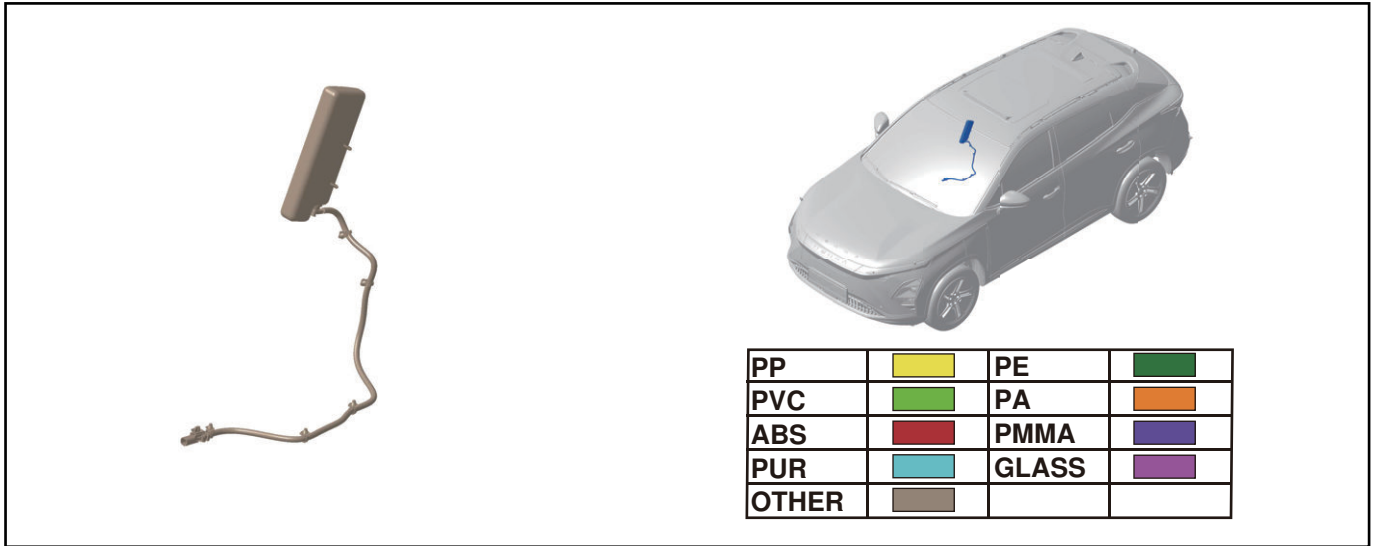

Front right airbag assembly:

Applicable Model	T19C EV
Position Description	Side of front right seat
Quantity	1
Weight (Kg)	0.4
Main Material	PA66, SAE 1510M HY-03-186
Fastener	Bolt
Number of Fasteners	2
Disassembly Tool	Socket wrench
Disassembly Method	Loosen the fasteners for disassembly
Recycling Pathways	The deployed airbag can be crushed, sorted, and reused.
Precautions for Disassembly	Wear protective equipment (goggles, gloves, etc.)

Safety warning sign:



## 2.1.7 Front Left Seat Belt Assembly

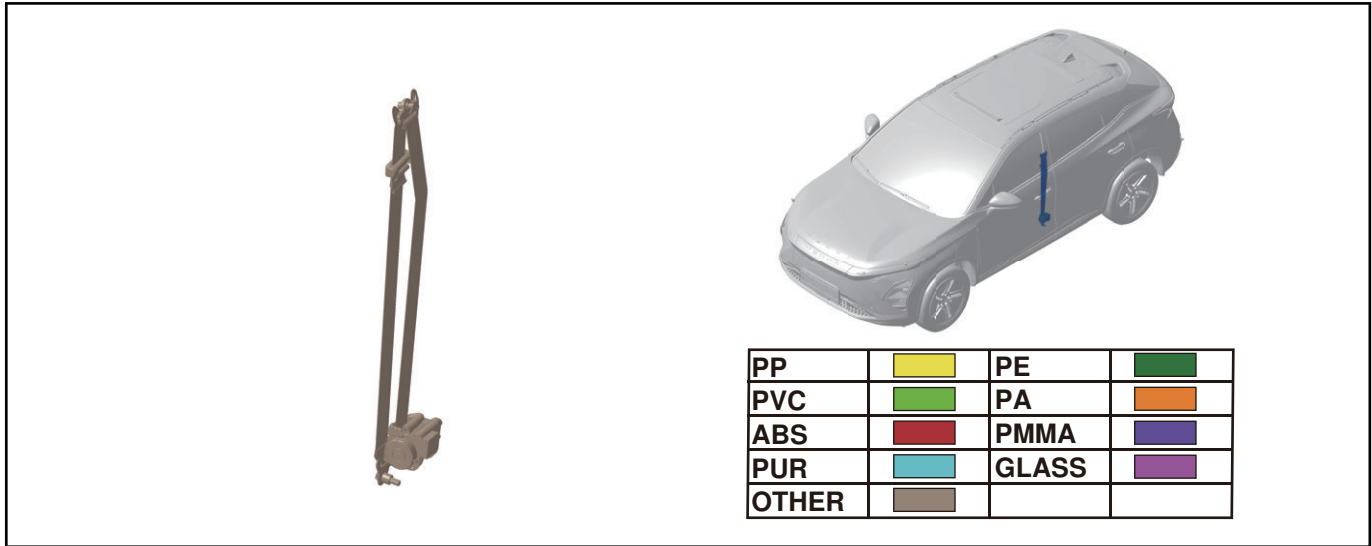

Front left seat belt assembly:

Applicable Model	T19C EV
Position Description	Lower side of left B-pillar
Quantity	1
Weight (Kg)	1.56
Main Material	Polyester filament, QSTE500TM
Fastener	Bolt
Number of Fasteners	1
Disassembly Tool	Socket wrench
Disassembly Method	Loosen the fasteners for disassembly
Recycling Pathways	Recycling and reuse of waste fiber products; Melting and reuse of metal materials
Precautions for Disassembly	Wear protective equipment (goggles, gloves, etc.)

Safety warning sign:



## 2.1.8 Front Right Seat Belt Assembly

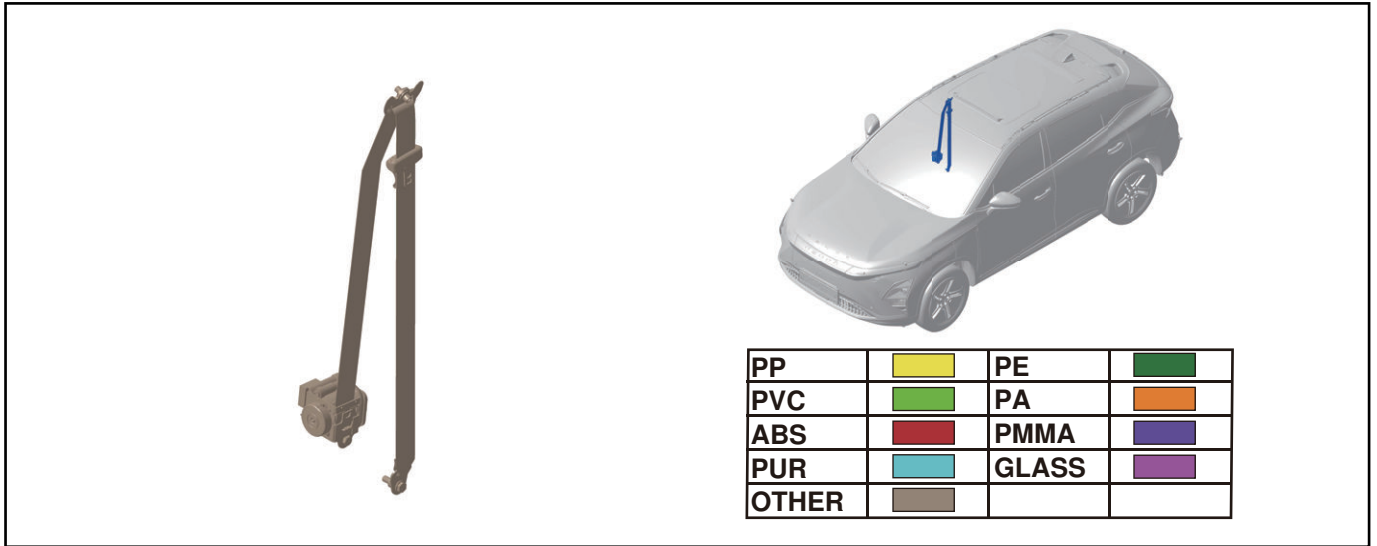

Front right seat belt assembly:

Applicable Model	T19C EV
Position Description	Lower side of right B-pillar
Quantity	1
Weight (Kg)	1.56
Main Material	Polyester filament, QSTE500TM
Fastener	Bolt
Number of Fasteners	1
Disassembly Tool	Socket wrench
Disassembly Method	Loosen the fasteners for disassembly
Recycling Pathways	Recycling and reuse of waste fiber products; Melting and reuse of metal materials
Precautions for Disassembly	Wear protective equipment (goggles, gloves, etc.)

Safety warning sign:



## 2.1.9 Rear Left Seat Belt Assembly

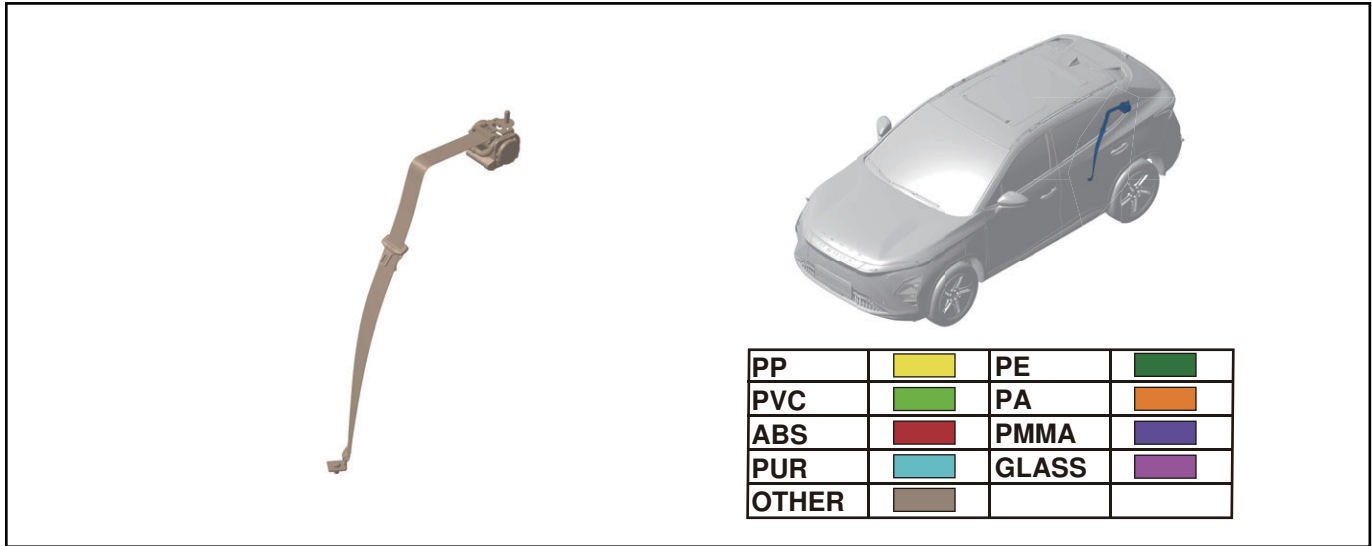

Rear left seat belt assembly:

Applicable Model	T19C EV
Position Description	On C-pillar sheet metal
Quantity	1
Weight (Kg)	1.26
Main Material	Polyester filament, QSTE500TM
Fastener	Bolt
Number of Fasteners	1
Disassembly Tool	Socket wrench
Disassembly Method	Loosen the fasteners for disassembly
Recycling Pathways	Recycling and reuse of waste fiber products; Melting and reuse of metal materials
Precautions for Disassembly	Wear protective equipment (goggles, gloves, etc.)

Safety warning sign:



### 2.1.10 Rear Right Seat Belt Assembly

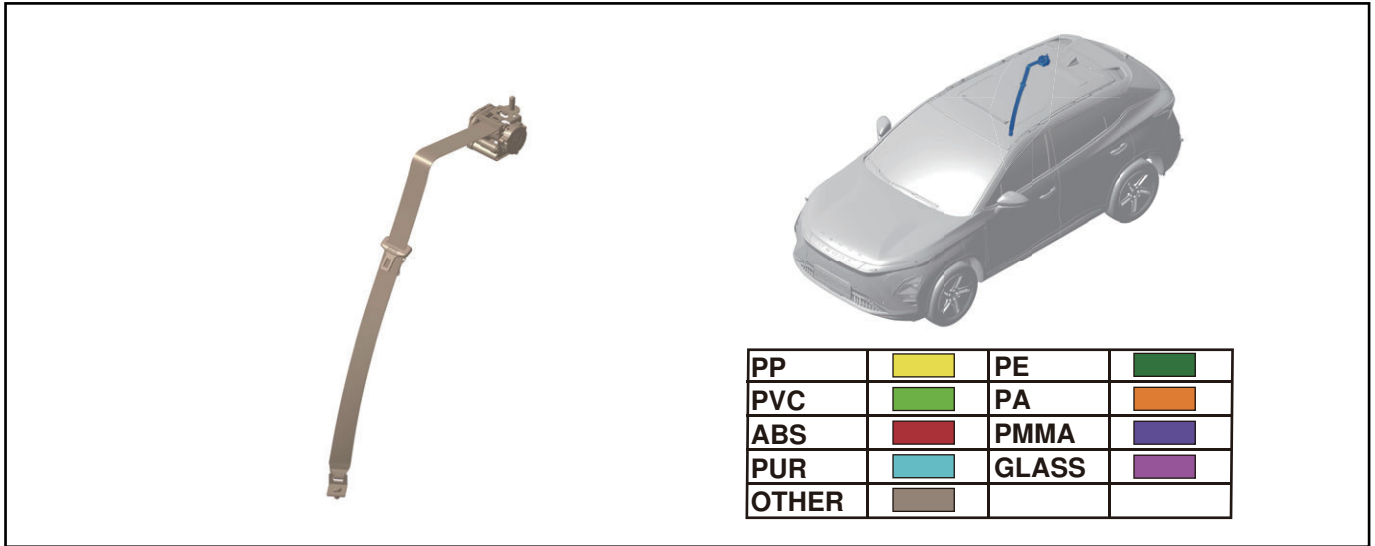

Rear right seat belt assembly:

Applicable Model	T19C EV
Position Description	On C-pillar sheet metal
Quantity	1
Weight (Kg)	1.26
Main Material	Polyester filament, QSTE500TM
Fastener	Bolt
Number of Fasteners	1
Disassembly Tool	Socket wrench
Disassembly Method	Loosen the fasteners for disassembly
Recycling Pathways	Recycling and reuse of waste fiber products; Melting and reuse of metal materials
Precautions for Disassembly	Wear protective equipment (goggles, gloves, etc.)

Safety warning sign:



### 2.1.11 Rear Center Seat Belt Assembly

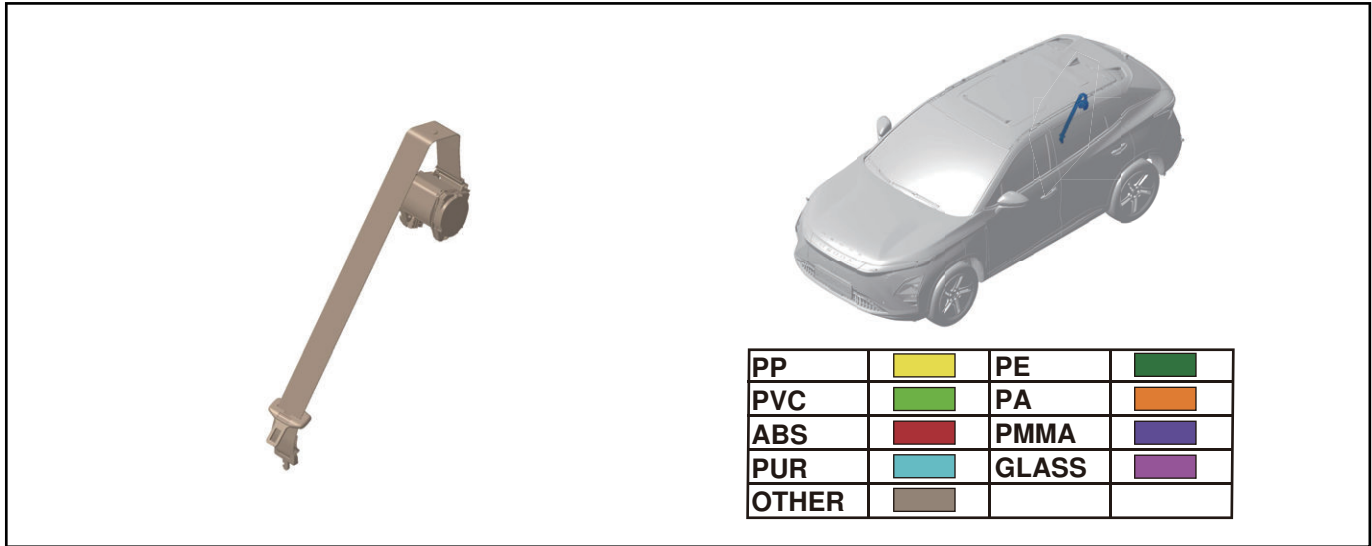

Rear center seat belt assembly:

Applicable Model	T19C EV
Position Description	On C-pillar sheet metal
Quantity	1
Weight (Kg)	0.6
Main Material	Polyester filament, QSTE500TM
Fastener	Bolt
Number of Fasteners	1
Disassembly Tool	Socket wrench
Disassembly Method	Loosen the fasteners for disassembly
Recycling Pathways	Recycling and reuse of waste fiber products; Melting and reuse of metal materials
Precautions for Disassembly	Wear protective equipment (goggles, gloves, etc.)

Safety warning sign:

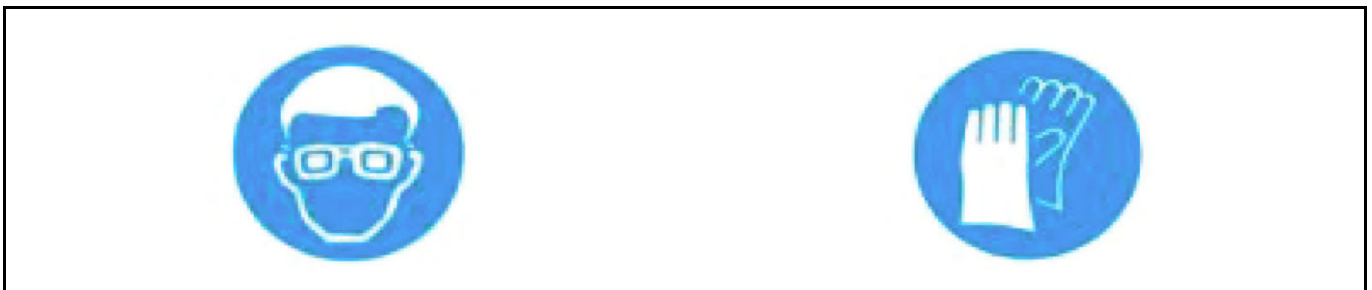

### 2.1.12 Battery

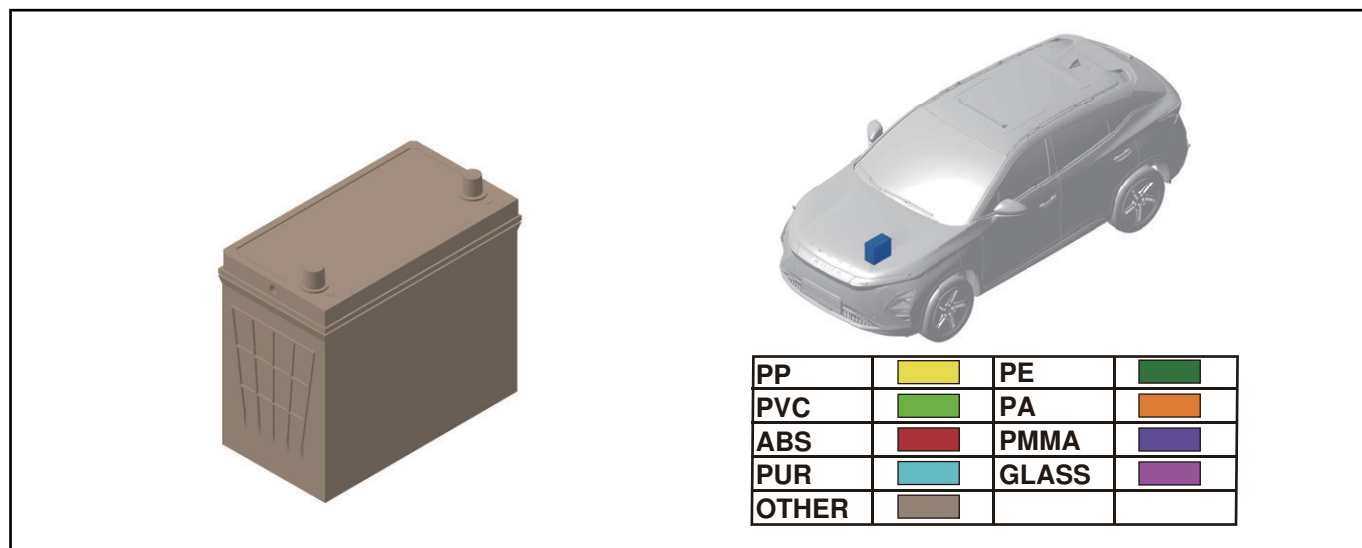

Battery:

Applicable Model	T19C EV
Position Description	Right side of the engine compartment
Quantity	1
Weight (Kg)	12.6
Main Material	Sulfuric acid solution, positive electrode active material, negative electrode active material
Fastener	Bolt
Number of Fasteners	4
Disassembly Tool	Socket wrench
Disassembly Method	<p>step 1: Remove the nuts from the positive and negative terminals of the battery and take off the positive and negative cables. Step 2: Remove the nuts from the pressure plate and take out the pull rod and pressure plate. Step 3: Remove the battery.</p>
Recycling Pathways	Deliver to battery recycling companies for disposal
Precautions for Disassembly	Avoid contact of acid with skin and eyes to prevent burns; it is highly flammable, so keep away from fire sources; it is a toxic substance, so prevent skin contact; avoid direct exposure of the battery to sunlight; wear protective equipment (goggles, gloves, etc.); operate in a well-ventilated environment.

Safety warning sign:

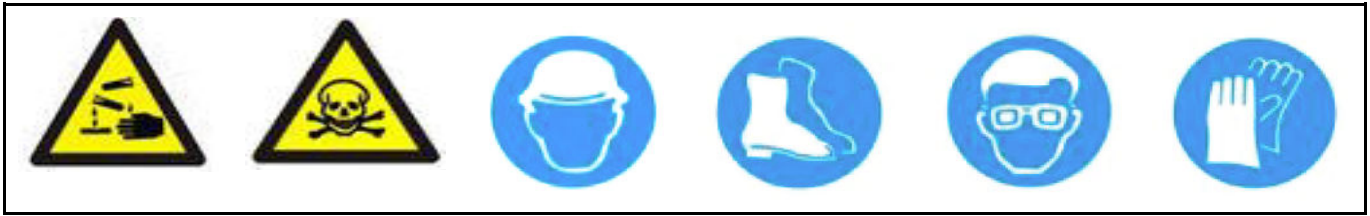
**Caution:**

Batteries contain highly corrosive liquids. Removal personnel should wear protective clothing and goggles to avoid contact of the acid with skin and eyes. No open flames, electrical sparks, bright lights, or smoking are allowed. Prevent the battery casing from being exposed to ultraviolet rays and do not allow the battery to be exposed to sunlight. Before removing the battery, it is necessary to turn off ignition switch and all electrical appliances, and first disconnect the negative cable, followed by the positive cable. Batteries are flammable, explosive, and toxic substances.

### 2.1.13 Power Battery Pack Assembly

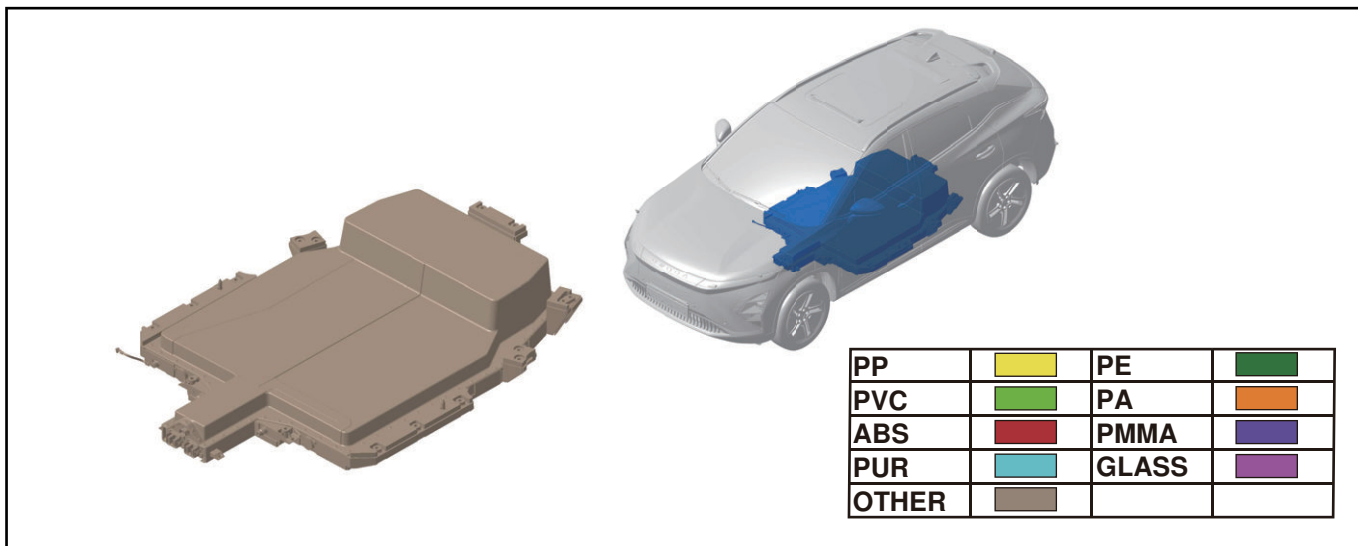

Power battery pack assembly:

Applicable Model	T19C EV
Position Description	Underbody
Quantity	1
Weight (Kg)	433.19
Main Material	Lithium ferrous phosphate P265-X, graphite powder_RZ-14-150-B
Fastener	Bolt
Number of Fasteners	14
Disassembly Tool	Socket wrench
Disassembly Method	After discharge, loosen the fasteners and remove (please refer to professional disassembly materials)
Recycling Pathways	Deliver to power battery recycling companies for disposal
Precautions for Disassembly	Wear protective equipment (goggles, gloves, etc.) for operation; Before disassembly, make sure that the vehicle is not in a high-voltage state and disconnect the positive or negative terminal of the power battery

Safety warning sign:



### 2.1.14 Tire Pressure Sensor Battery

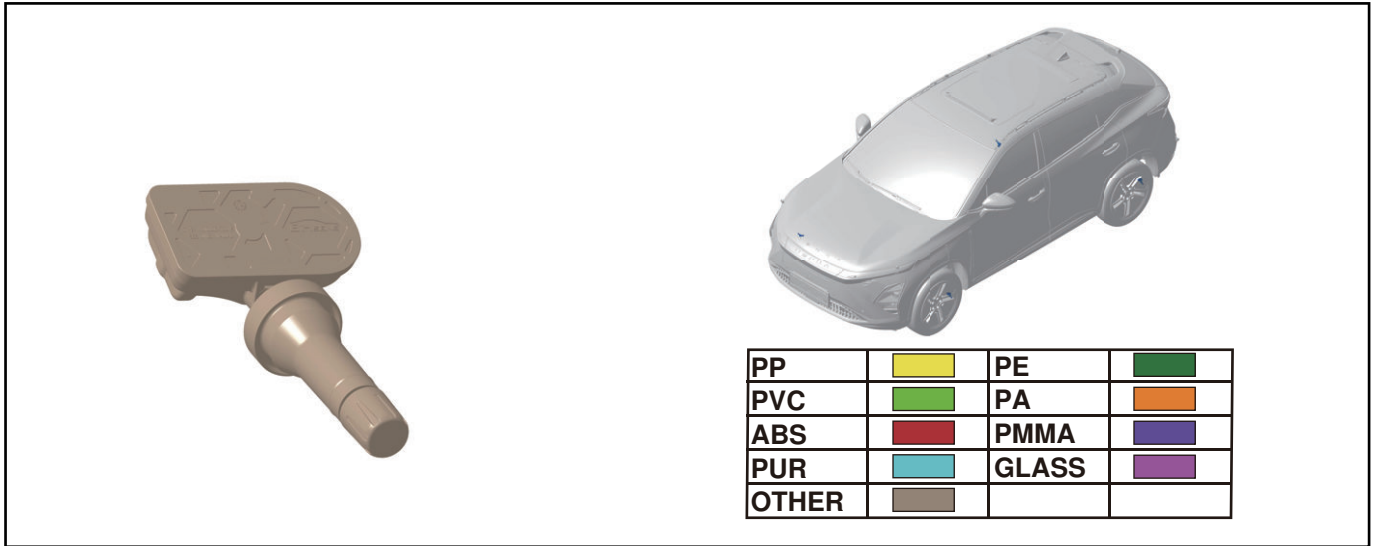

Tire pressure sensor battery:

Applicable Model	T19C EV
Position Description	Among the four tires
Quantity	4
Weight (Kg)	0.03/pc
Main Material	PA66-GF30, EPDM
Fastener	Nut
Number of Fasteners	1
Disassembly Tool	Socket wrench
Disassembly Method	Loosen the fasteners for disassembly
Recycling Pathways	Deliver to battery recycling companies for disposal
Precautions for Disassembly	It is highly flammable, so keep away from fire sources; it is a toxic substance, so prevent skin contact;

Safety warning sign:



## 2.1.15 Remote Controller Battery

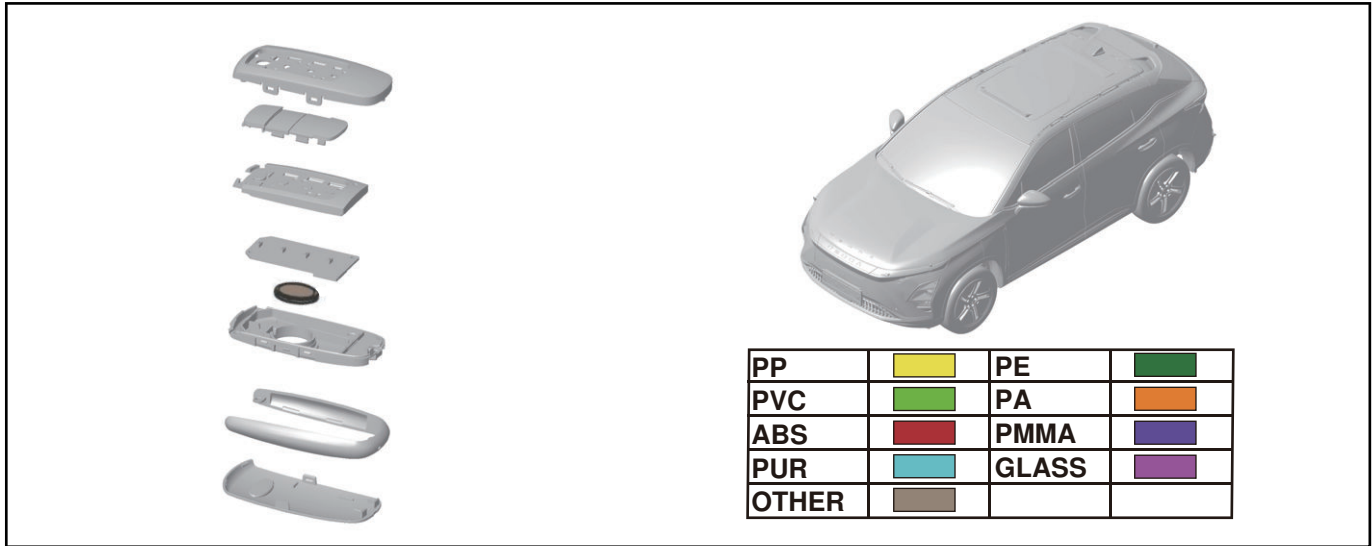

Remote controller battery:

Applicable Model	T19C EV
Position Description	Inside the key housing
Quantity	2
Weight (Kg)	-
Main Material	Lithium battery
Fastener	Metal clip inside the key
Number of Fasteners	-
Disassembly Tool	-
Disassembly Method	Loosen the fasteners for disassembly
Recycling Pathways	Deliver to battery recycling companies for disposal
Precautions for Disassembly	It is highly flammable, so keep away from fire sources; it is a toxic substance, so prevent skin contact;

Safety warning sign:



### 2.1.16 Tire

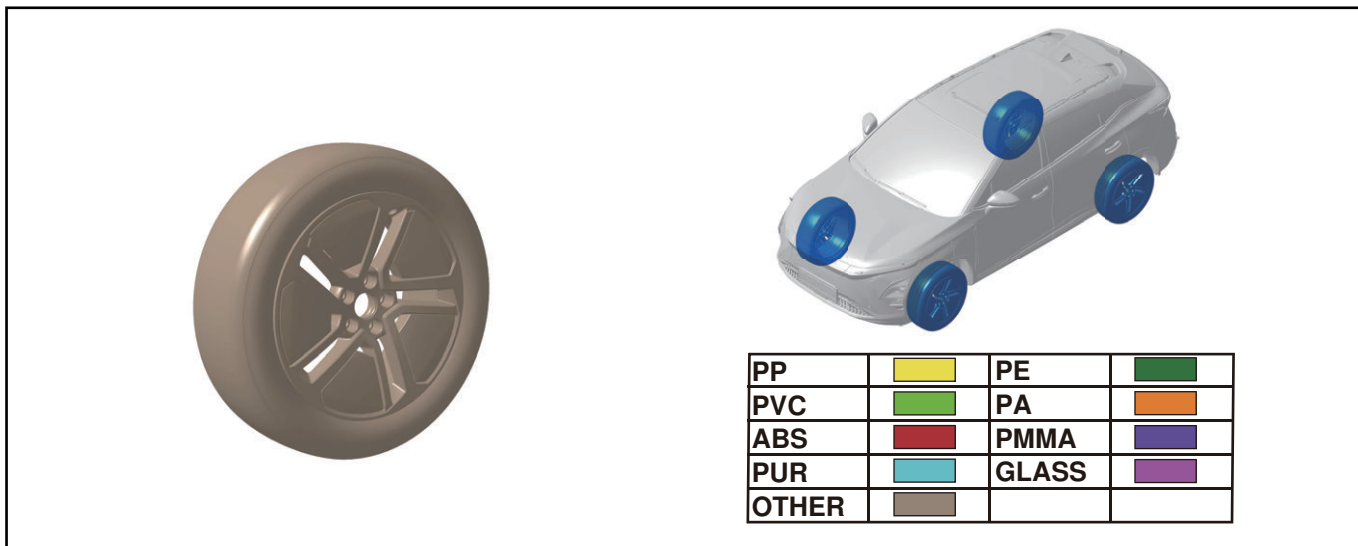

Tire:

Applicable Model	T19C EV
Position Description	Front/rear/left/right of the vehicle body
Quantity	4
Weight (Kg)	12.1/pc
Main Material	Rubber
Fastener	Bolt
Number of Fasteners	20
Disassembly Tool	Pneumatic wrench, vehicle lift, tire changer
Disassembly Method	Use a pneumatic wrench to remove the retaining bolts, and then remove the tire and hub; use tire dismantling equipment such as a tire changer to remove the tire
Recycling Pathways	Reuse of crumb rubber made from waste rubber; reuse of reclaimed rubber from waste rubber
Precautions for Disassembly	Wear protective equipment (goggles, gloves, etc.)

Safety warning sign:

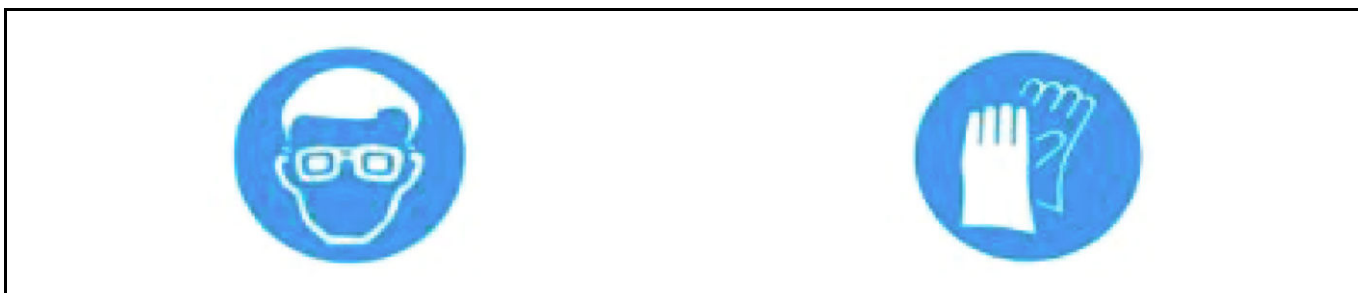

### 2.1.17 Spare Tire

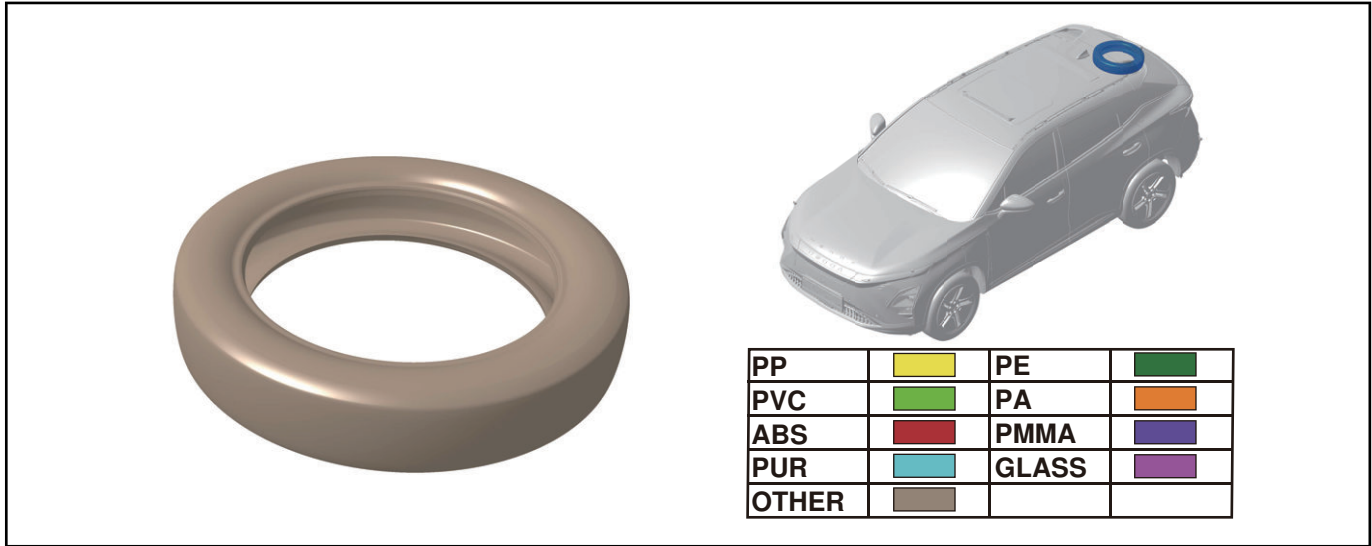

Spare tire:

Applicable Model	T19C EV
Position Description	Under the luggage compartment protector
Quantity	1
Weight (Kg)	5.7
Main Material	Rubber
Fastener	Nut
Number of Fasteners	1
Disassembly Tool	Tire changer
Disassembly Method	Loosen the fasteners for disassembly; use tire dismantling equipment such as a tire changer to remove the tire
Recycling Pathways	Reuse of crumb rubber made from waste rubber; reuse of reclaimed rubber from waste rubber
Precautions for Disassembly	Wear protective equipment (goggles, gloves, etc.)

Safety warning sign:



### 2.1.18 Coolant

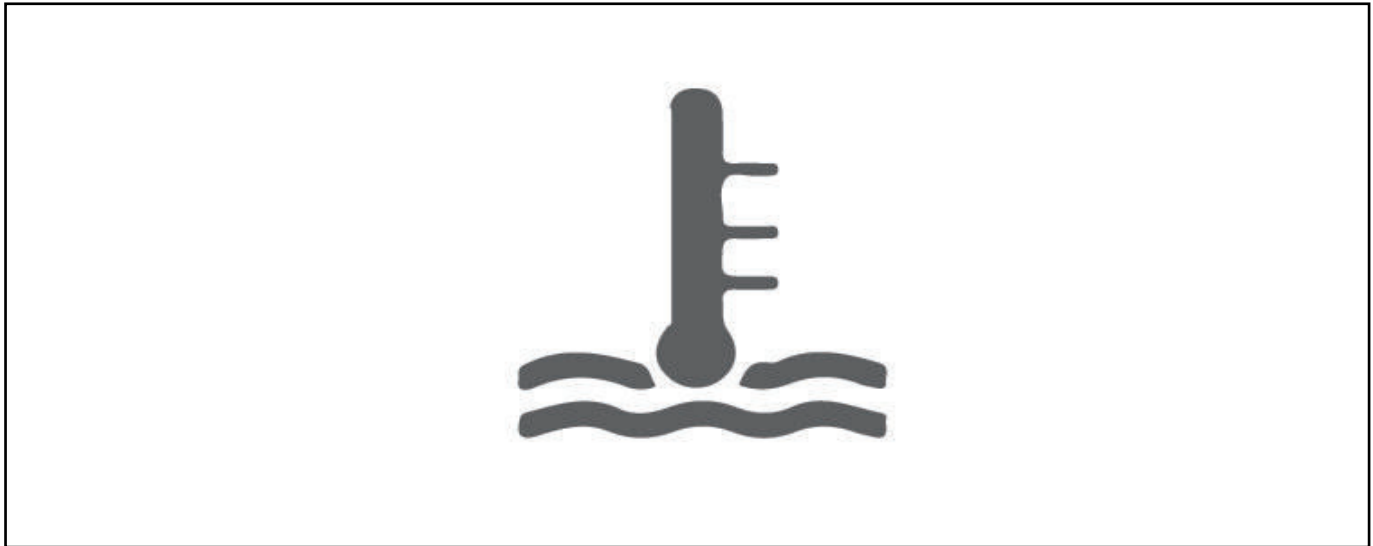

Coolant:

Applicable Model	T19C EV
Position Description	In the components related to the cooling system
Quantity	1
Weight (Kg)	-
Main Material	Coolant
Fastener	-
Number of Fasteners	-
Disassembly Tool	Evacuation and suction equipment
Disassembly Method	Unscrew the fuel filler port and use the evacuation and suction equipment to drain
Recycling Pathways	Deliver to qualified coolant recycling companies for disposal
Precautions for Disassembly	Wear protective equipment (goggles, gloves, etc.); operate in a well-ventilated environment; it is a toxic substance, so prevent skin contact

Safety warning sign:



## 2.1.19 Brake Fluid



Brake fluid:

Applicable Model	T19C EV
Position Description	In the brake fluid reservoir and brake lines
Quantity	1
Weight (Kg)	-
Main Material	Brake fluid
Fastener	-
Number of Fasteners	-
Disassembly Tool	Evacuation and suction equipment
Disassembly Method	Unscrew the fuel filler port and use the evacuation and suction equipment to drain
Recycling Pathways	Deliver to qualified brake fluid recycling companies for disposal
Precautions for Disassembly	Wear protective equipment (goggles, gloves, etc.); operate in a well-ventilated environment; it is a toxic substance, so prevent skin contact

Safety warning sign:



### 2.1.20 Shock Absorber Oil

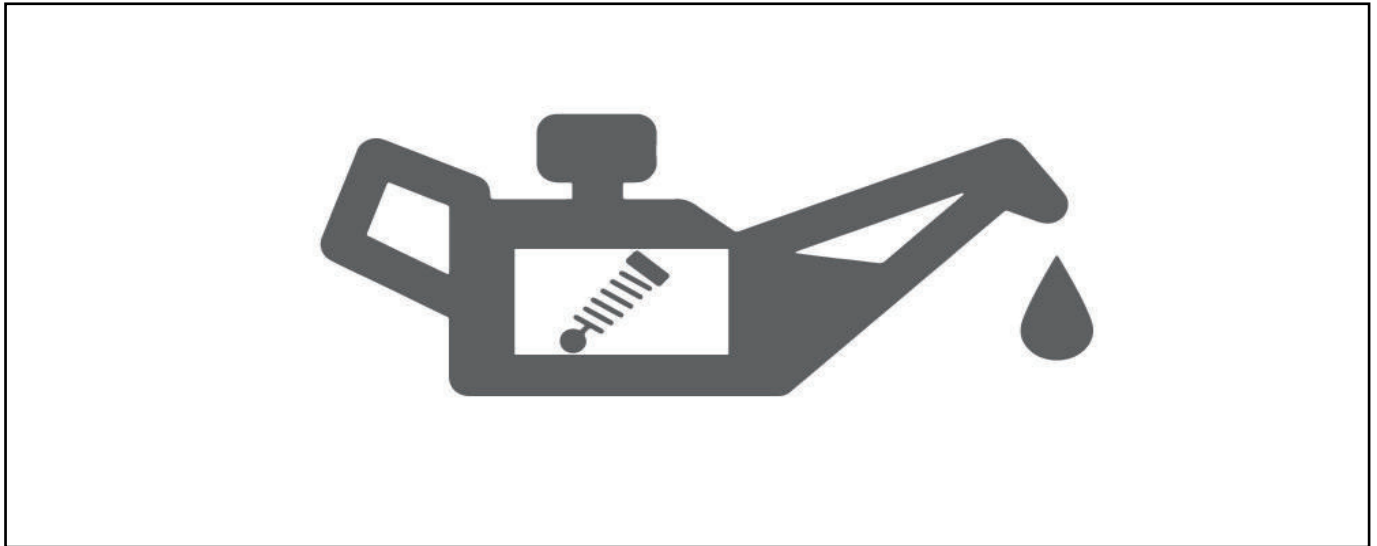

Shock absorber oil:

Applicable Model	T19C EV
Position Description	Inside the shock absorber
Quantity	Front shock absorber 2, rear shock absorber 2
Weight (Kg)	-
Main Material	Shock absorber oil
Fastener	-
Number of Fasteners	-
Disassembly Tool	Evacuation and suction equipment
Disassembly Method	Unscrew the fuel filler port and use the evacuation and suction equipment to drain
Recycling Pathways	Deliver to qualified waste oil recycling companies for disposal
Precautions for Disassembly	Wear protective equipment (goggles, gloves, etc.)

Safety warning sign:



## 2.1.21 Windshield Washer Fluid

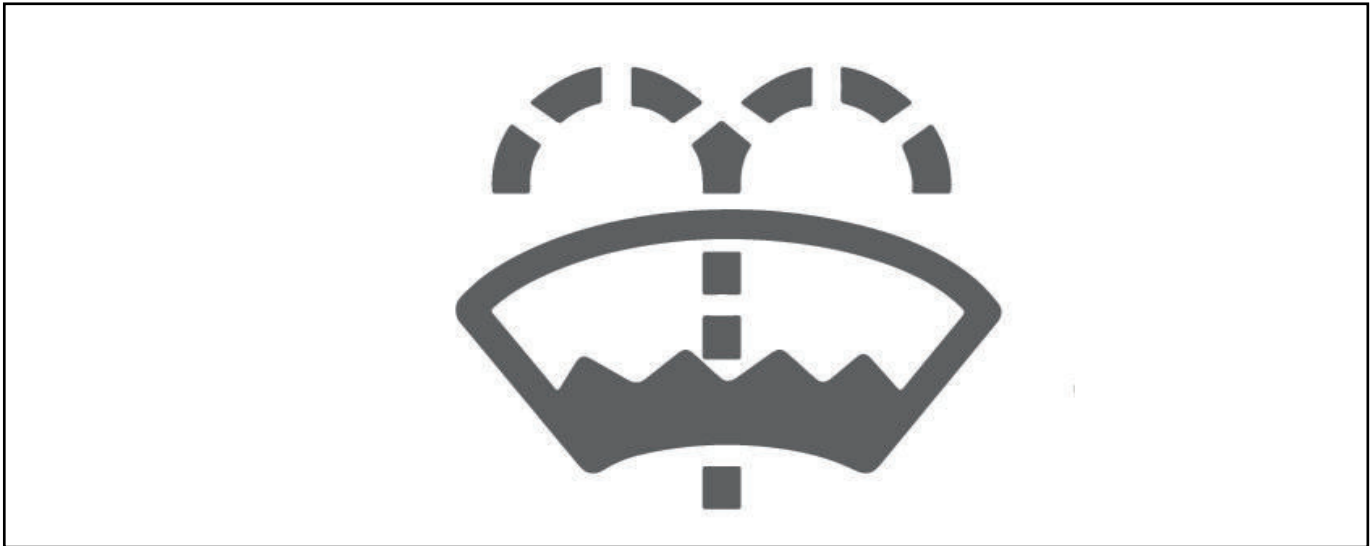

Windshield washer fluid:

Applicable Model	T19C EV
Position Description	Washer fluid reservoir
Quantity	1
Weight (Kg)	-
Main Material	Windshield washer fluid
Fastener	-
Number of Fasteners	-
Disassembly Tool	Evacuation and suction equipment
Disassembly Method	Unscrew the fuel filler port and use the evacuation and suction equipment to drain
Recycling Pathways	Deliver to qualified waste fluid recycling companies for disposal
Precautions for Disassembly	Wear protective equipment (goggles, gloves, etc.); it is a toxic substance, prevent skin contact

Safety warning sign:

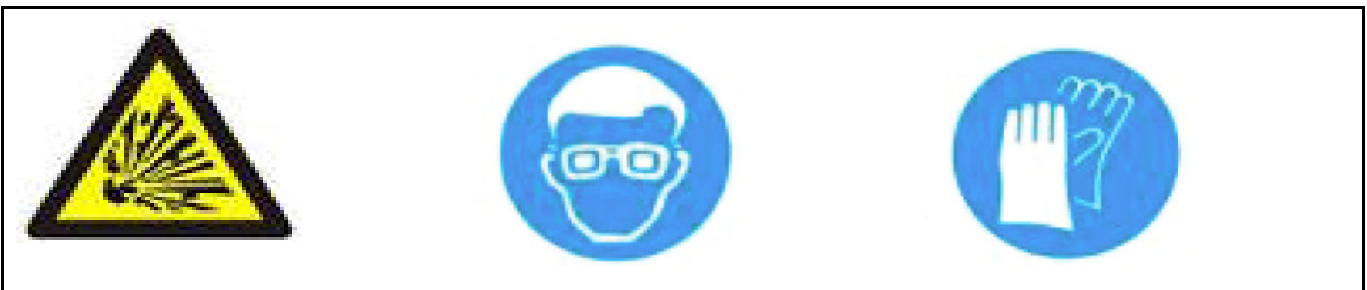

### 2.1.22 R134a Refrigerant

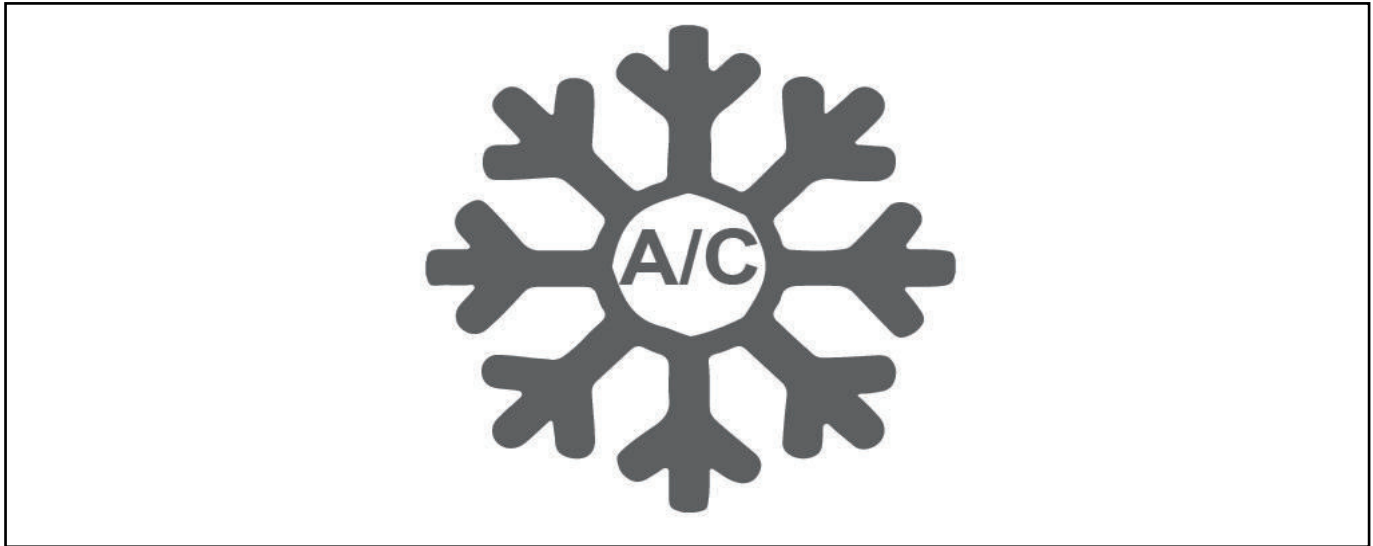

R134a refrigerant:

Applicable Model	T19C EV
Position Description	Inside the high/low pressure pipes of the A/C
Quantity	1
Weight (Kg)	-
Main Material	Refrigerant
Fastener	-
Number of Fasteners	-
Disassembly Tool	Refrigerant discharging device
Disassembly Method	Use specialized refrigerant equipment for discharging
Recycling Pathways	Deliver qualified refrigerant recycling companies for disposal
Precautions for Disassembly	Wear protective equipment (goggles, gloves, etc.); operate in a well-ventilated environment; it is a toxic substance, so prevent skin contact

Safety warning sign:

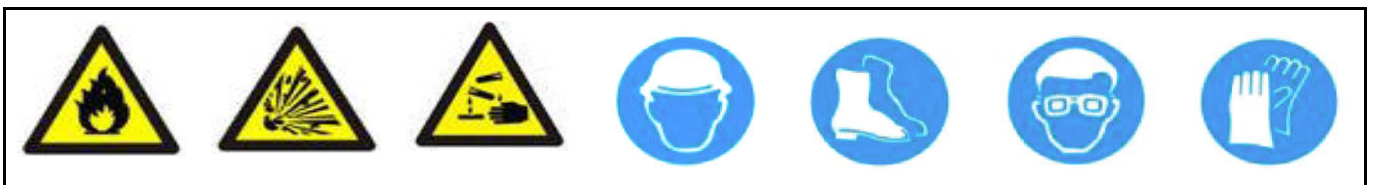

## 2.2 Removal

### 2.2.1 Front Bumper Assembly

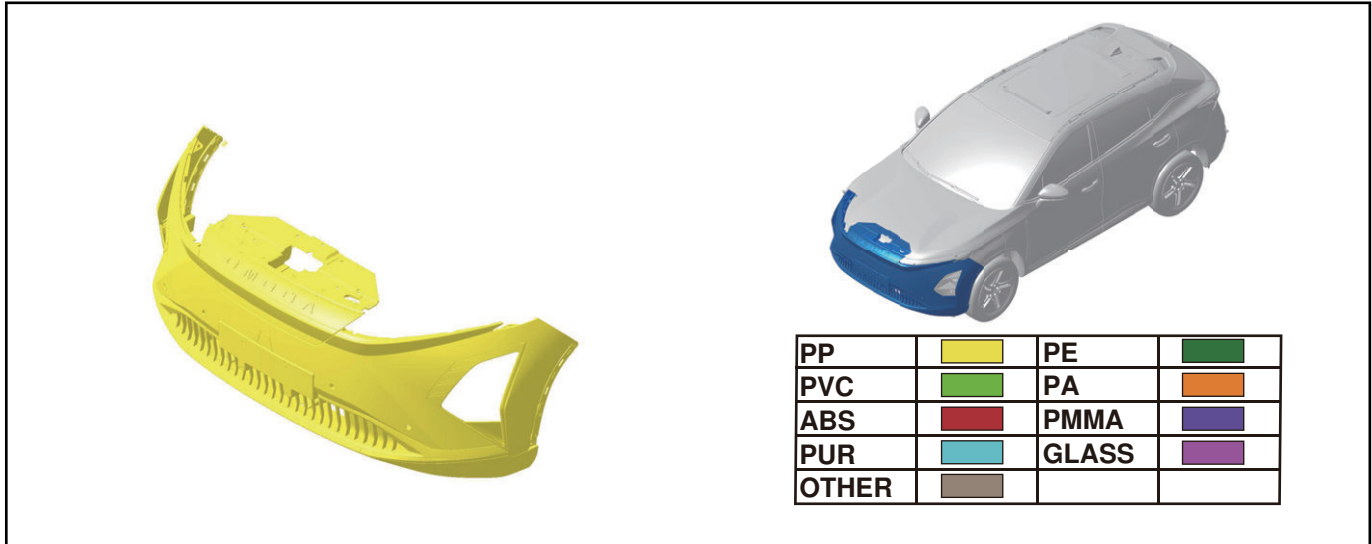

Front bumper assembly:

Applicable Model	T19C EV
Position Description	Front bumper is located at the front of vehicle
Quantity	1
Weight (Kg)	9.3
Main Material	PP+EPDM-T20
Fastener	Bolt
Number of Fasteners	9
Disassembly Tool	Socket wrench, cross tip screwdriver
Disassembly Method	Loosen the fasteners for disassembly
Recycling Pathways	Modified recycling of waste plastics
Precautions for Disassembly	Wear protective equipment (goggles, gloves, etc.)

Safety warning sign:



## 2.2.2 Rear Bumper Assembly

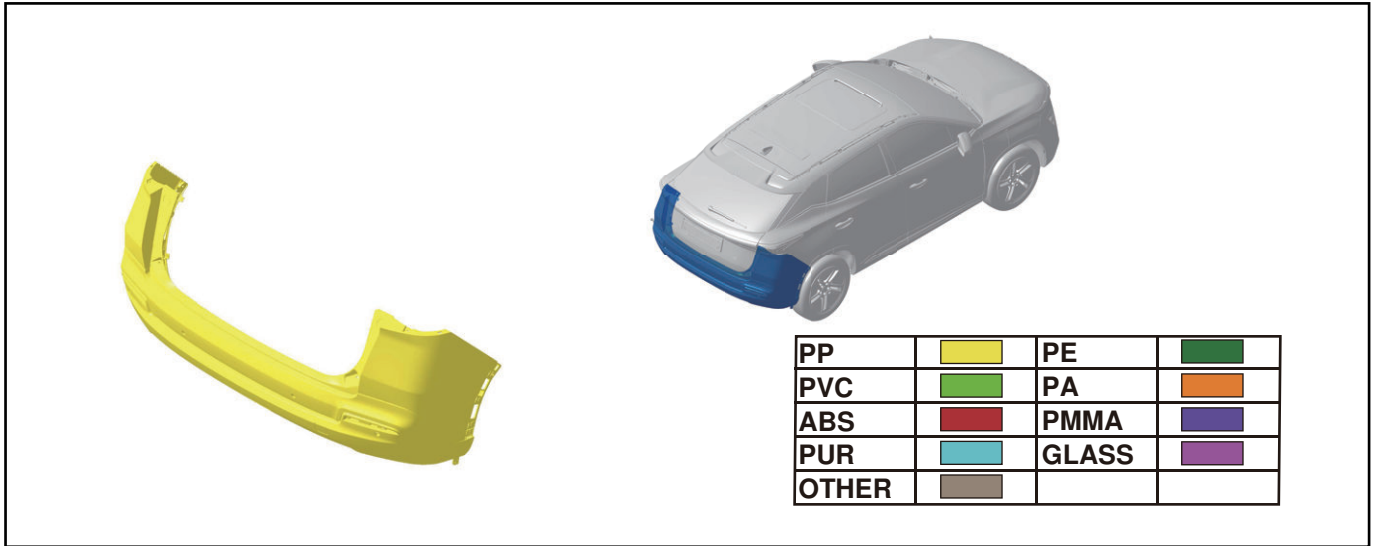

Rear bumper assembly:

Applicable Model	T19C EV
Position Description	Rear bumper is located at the rear of vehicle
Quantity	1
Weight (Kg)	4.41
Main Material	PP+EPDM-T20
Fastener	Bolt, screw
Number of Fasteners	15
Disassembly Tool	Cross tip screwdriver, socket wrench
Disassembly Method	Loosen the fasteners for disassembly
Recycling Pathways	Modified recycling of waste plastics
Precautions for Disassembly	Wear protective equipment (goggles, gloves, etc.)

Safety warning sign:



## 2.2.3 Front Windshield Lower Trim Panel

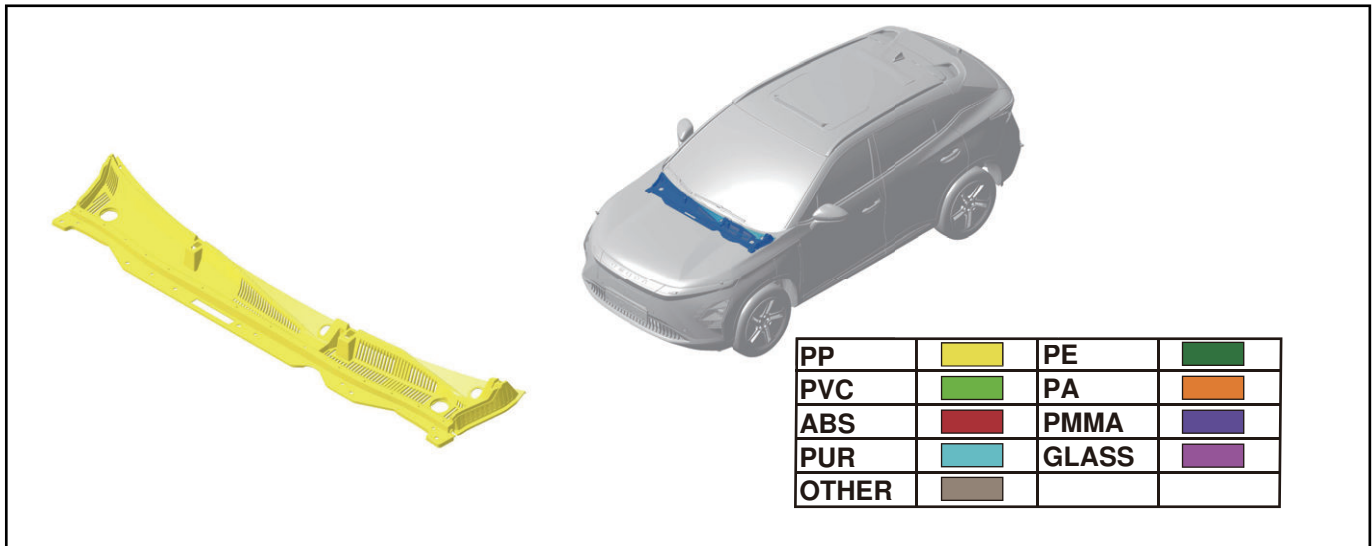

Front windshield lower trim panel:

Applicable Model	T19C EV
Position Description	Front part of front windshield
Quantity	1
Weight (Kg)	0.92
Main Material	PP-TD20
Fastener	Screw
Number of Fasteners	5
Disassembly Tool	Cross tip screwdriver
Disassembly Method	Loosen the fasteners for disassembly
Recycling Pathways	Modified recycling of waste plastics
Precautions for Disassembly	Wear protective equipment (goggles, gloves, etc.)

Safety warning sign:



### 2.2.4 Front Windshield Lower Trim Panel Cover Plate

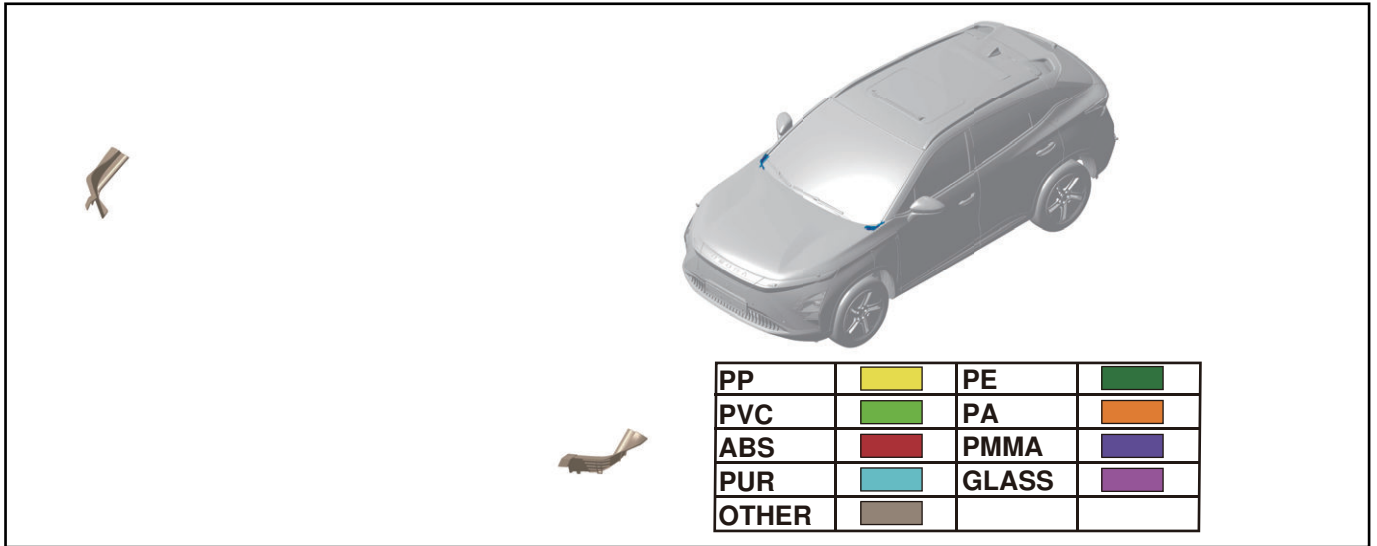

Front windshield lower trim panel cover plate:

Applicable Model	T19C EV
Position Description	Located on both sides of front windshield lower trim panel
Quantity	1 on each side
Weight (Kg)	0.023/pc
Main Material	TPV
Fastener	Clip
Number of Fasteners	8
Disassembly Tool	Clip remover
Disassembly Method	Loosen the fasteners for disassembly
Recycling Pathways	Modified recycling of waste plastics
Precautions for Disassembly	Wear protective equipment (goggles, gloves, etc.)

Safety warning sign:

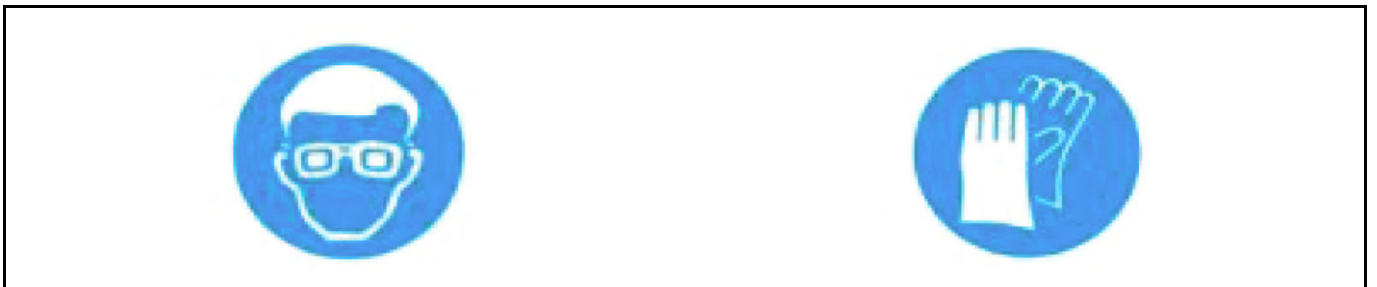

### 2.2.5 Wheel Hub Outer Cover

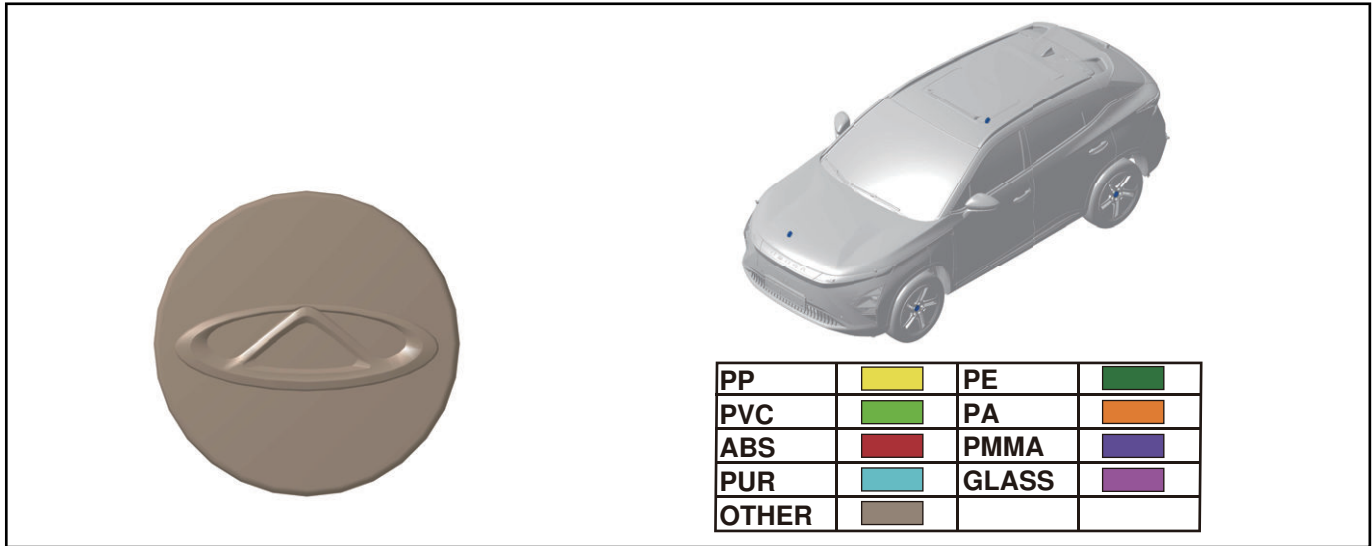

Wheel hub outer cover:

Applicable Model	T19C EV
Position Description	Wheel hub outer covers are located at the center of four wheels
Quantity	4
Weight (Kg)	0.017/pc
Main Material	ABS, aluminum
Fastener	-
Number of Fasteners	-
Disassembly Tool	-
Disassembly Method	Directly remove
Recycling Pathways	Modified recycling of waste plastics; melting and reuse of metal materials
Precautions for Disassembly	Wear protective equipment (goggles, gloves, etc.)

Safety warning sign:



## 2.2.6 Charging Port Cover

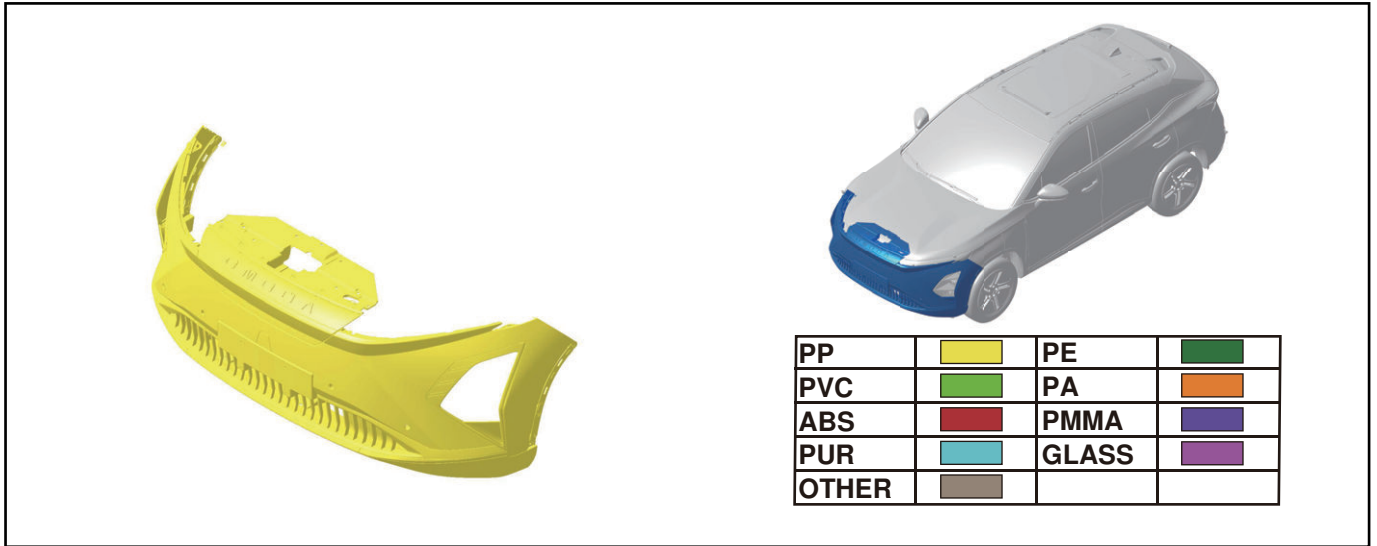

Charging port cover:

Applicable Model	T19C EV
Position Description	The charging port cover is located above the bumper
Quantity	1
Weight (Kg)	1.5
Main Material	PP+EPDM-TD20
Fastener	Screw
Number of Fasteners	2
Disassembly Tool	Cross tip screwdriver
Disassembly Method	Loosen the fasteners for disassembly
Recycling Pathways	Modified recycling of waste plastics
Precautions for Disassembly	Wear protective equipment (goggles, gloves, etc.)

Safety warning sign:



## 2.2.7 Front Splash Guard

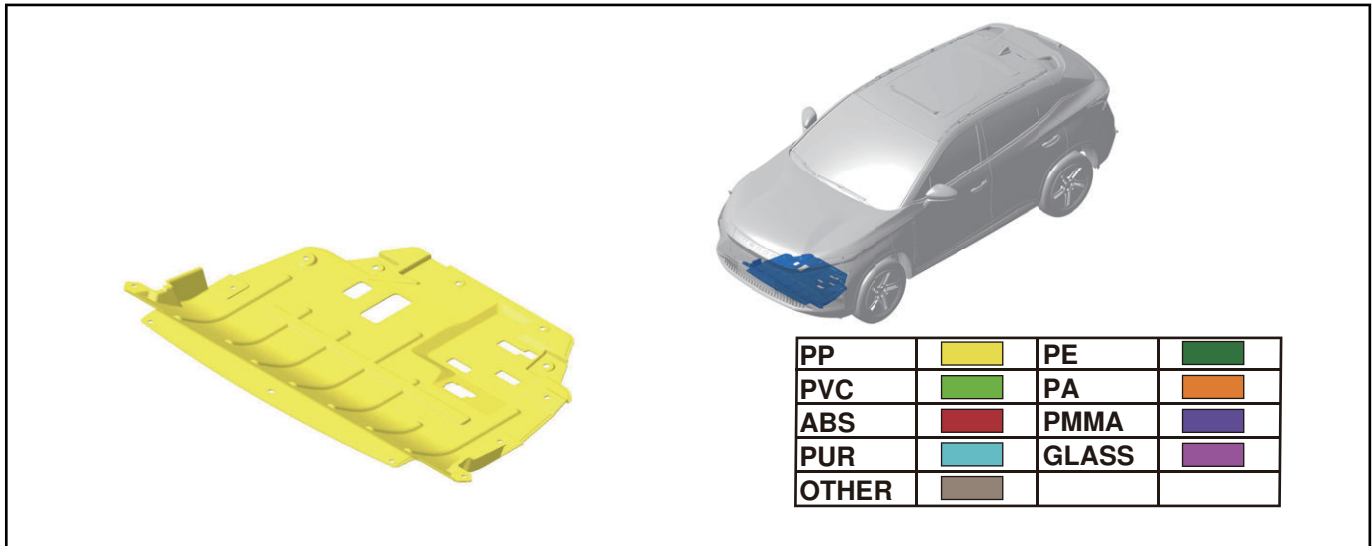

Front splash guard:

Applicable Model	T19C EV
Position Description	The bottom of the engine
Quantity	1
Weight (Kg)	1.06
Main Material	PP, PET
Fastener	Bolt, clamp
Number of Fasteners	13
Disassembly Tool	Socket wrench, cross tip screwdriver
Disassembly Method	Loosen the fasteners for disassembly
Recycling Pathways	Modified recycling of waste plastics; recycling of mixed plastics through crushing and separation
Precautions for Disassembly	Wear protective equipment (goggles, gloves, etc.)

Safety warning sign:



## 2.2.8 Front Wheel Protector

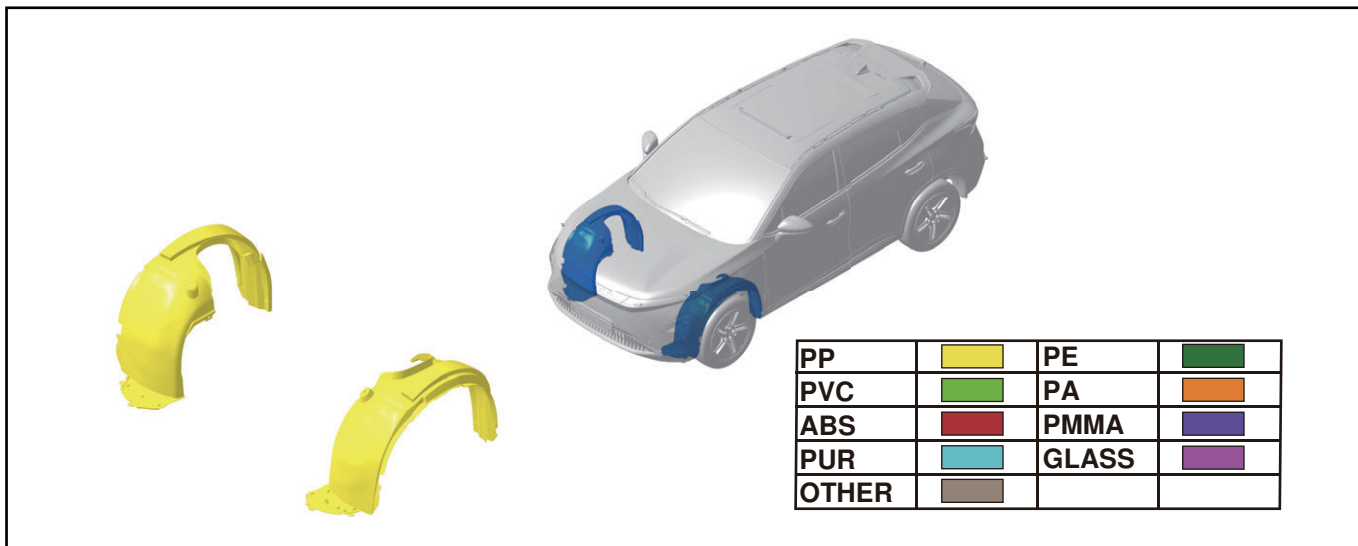

Front wheel protector:

Applicable Model	T19C EV
Position Description	Front wheel protectors are located at the front of vehicle, above the two front wheels
Quantity	1 on each side
Weight (Kg)	0.9/pc
Main Material	PP+EPDM, PP+PET
Fastener	Screw, clip
Number of Fasteners	13
Disassembly Tool	Cross tip screwdriver, clip remover
Disassembly Method	Loosen the fasteners for disassembly
Recycling Pathways	Modified recycling of waste plastics; recycling of mixed plastics through crushing and separation
Precautions for Disassembly	Wear protective equipment (goggles, gloves, etc.)

Safety warning sign:



## 2.2.9 Rear Wheel Protector

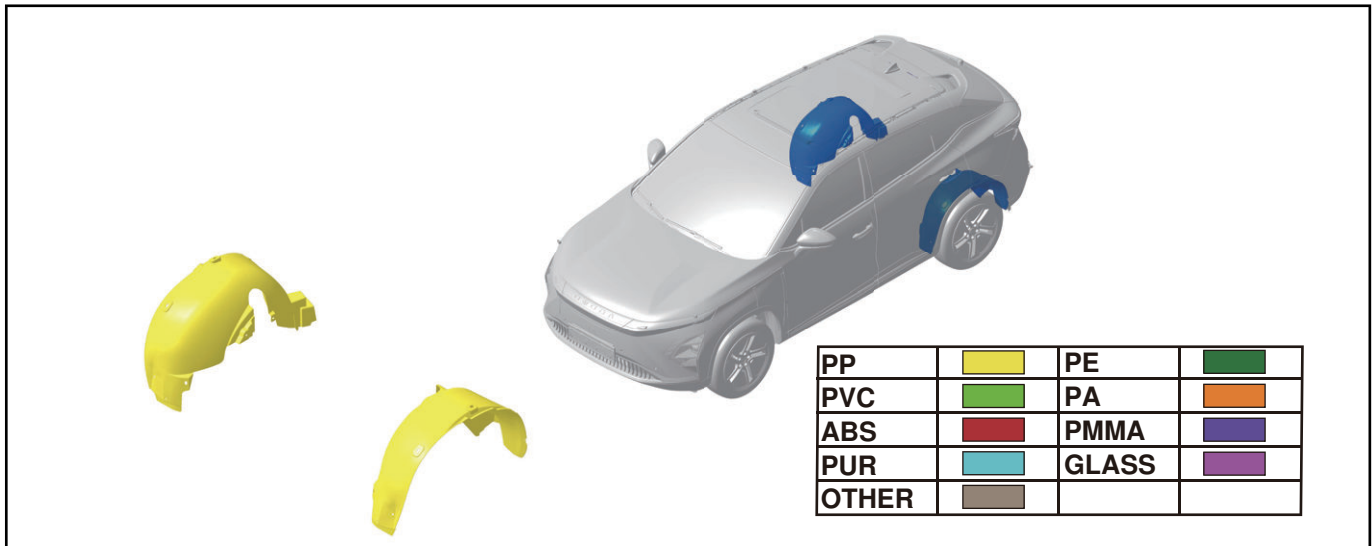

Rear wheel protector:

Applicable Model	T19C EV
Position Description	Rear wheel protectors are located at the rear of vehicle, above the two rear wheels
Quantity	1 on each side
Weight (Kg)	0.82/pc
Main Material	PP+EPDM
Fastener	Snap fastener, screw, nut
Number of Fasteners	11
Disassembly Tool	Socket wrench, cross tip screwdriver
Disassembly Method	Loosen the fasteners for disassembly
Recycling Pathways	Modified recycling of waste plastics
Precautions for Disassembly	Wear protective equipment (goggles, gloves, etc.)

Safety warning sign:

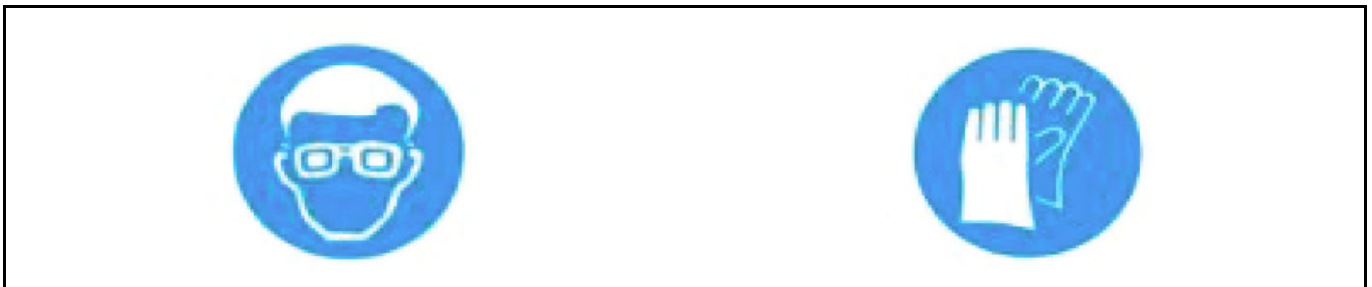

### 2.2.10 Instrument Panel

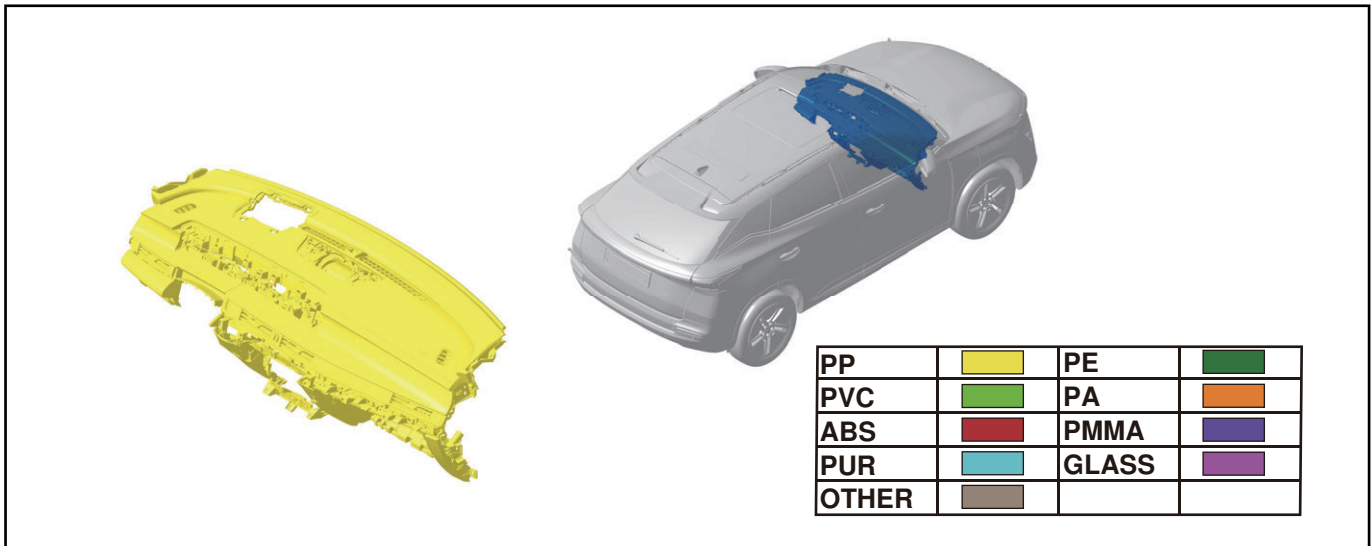

Instrument panel:

Applicable Model	T19C EV
Position Description	Front part inside the vehicle
Quantity	1
Weight (Kg)	9.63
Main Material	PP+EPDM-T20, PP+LGF20
Fastener	Bolt, screw, clip
Number of Fasteners	-
Disassembly Tool	Socket wrench, clip remover
Disassembly Method	Loosen the fasteners for disassembly
Recycling Pathways	Modified recycling of waste plastics; recycling of mixed plastics through crushing and separation
Precautions for Disassembly	Wear protective equipment (goggles, gloves, etc.)

Safety warning sign:



## 2.2.11 Auxiliary Fascia Console Body Assembly

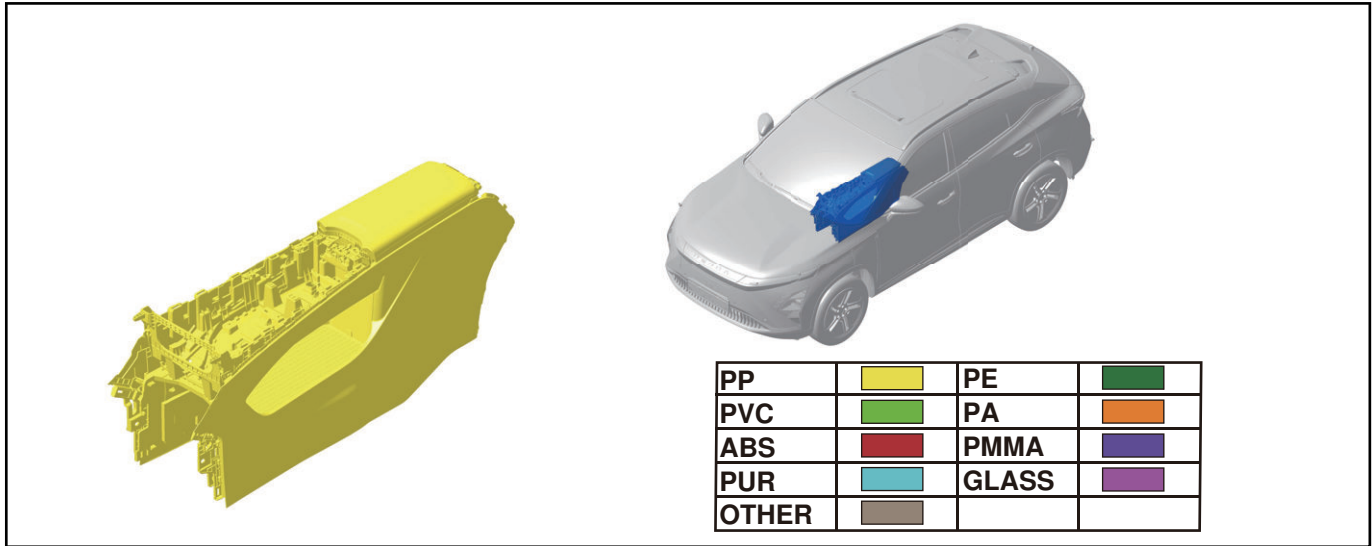

Auxiliary fascia console body assembly:

Applicable Model	T19C EV
Position Description	The auxiliary fascia console body assembly is located inside the vehicle
Quantity	1
Weight (Kg)	6.3
Main Material	PP+EPDM-T20, PP-LGF20
Fastener	Screw, bolt
Number of Fasteners	12
Disassembly Tool	Cross tip screwdriver, socket wrench
Disassembly Method	Loosen the fasteners for disassembly
Recycling Pathways	Modified recycling of waste plastics; recycling of mixed plastics through crushing and separation
Precautions for Disassembly	Wear protective equipment (goggles, gloves, etc.)

Safety warning sign:



## 2.2.12 Glove Box Assembly

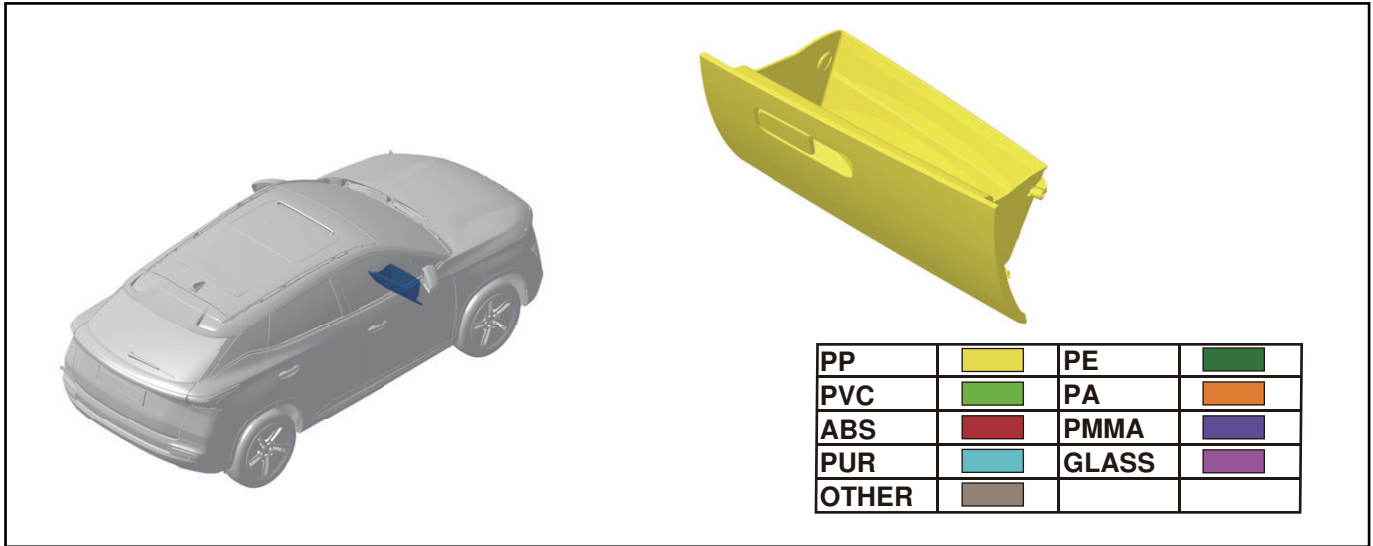

Glove box assembly:

Applicable Model	T19C EV
Position Description	Glove box is located on the left side of instrument panel
Quantity	1
Weight (Kg)	1.21
Main Material	PP+EPDM-T20
Fastener	Clip
Number of Fasteners	2
Disassembly Tool	Flat tip screwdriver
Disassembly Method	Loosen the fasteners for disassembly
Recycling Pathways	Modified recycling of waste plastics
Precautions for Disassembly	Wear protective equipment (goggles, gloves, etc.)

Safety warning sign:



## 2.2.13 Front Windshield Assembly

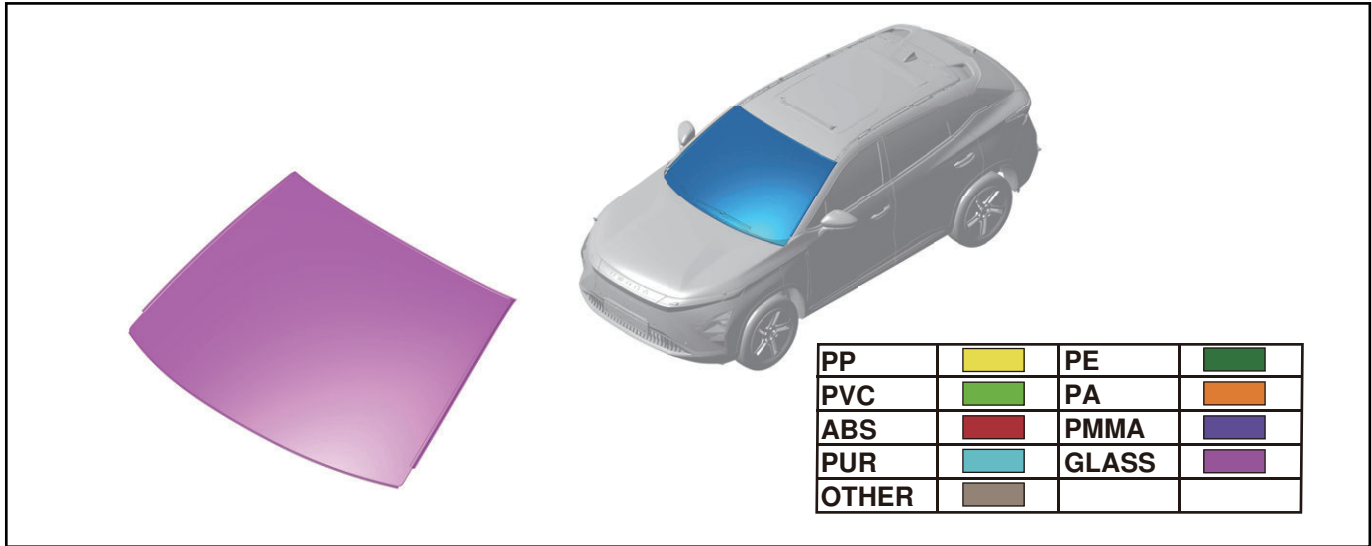

Front windshield assembly:

Applicable Model	T19C EV
Position Description	The glass between left and right A-pillars
Quantity	1
Weight (Kg)	14.18
Main Material	Glass
Fastener	-
Number of Fasteners	-
Disassembly Tool	Windshield removal tool kit
Disassembly Method	Use a windshield removal wire to cut through the adhesive material around the perimeter; disassemble using the windshield removal tool kit
Recycling Pathways	Tempered glass foam molding technology
Precautions for Disassembly	Wear protective equipment (goggles, gloves, etc.)

Safety warning sign:



### 2.2.14 Front Door Glass Assembly

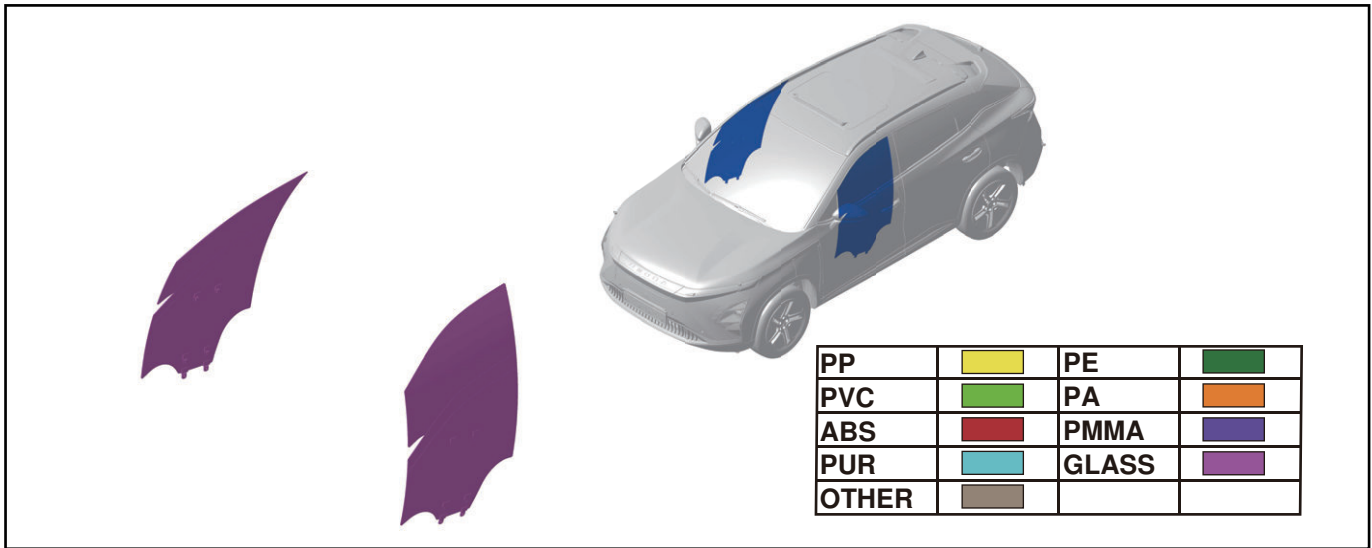

Front door glass assembly:

Applicable Model	T19C EV
Position Description	On the front door
Quantity	2
Weight (Kg)	2.86/pc
Main Material	Glass
Fastener	Clip
Number of Fasteners	2
Disassembly Tool	Cross tip screwdriver
Disassembly Method	Loosen the clips for disassembly
Recycling Pathways	Tempered glass foam molding technology
Precautions for Disassembly	Wear protective equipment (goggles, gloves, etc.)

Safety warning sign:



## 2.2.15 Rear Door Glass Assembly

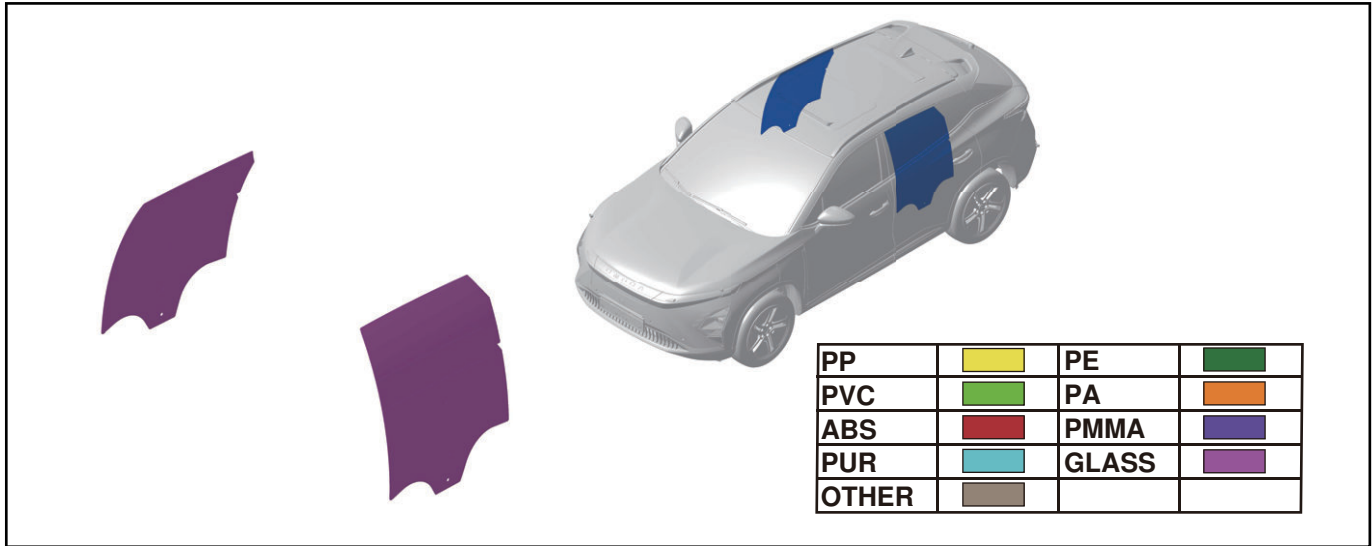

Rear door glass assembly:

Applicable Model	T19C EV
Position Description	On the rear door
Quantity	2
Weight (Kg)	2.25/pc
Main Material	Glass
Fastener	Clip
Number of Fasteners	2
Disassembly Tool	Cross tip screwdriver
Disassembly Method	Loosen the clips for disassembly
Recycling Pathways	Tempered glass foam molding technology
Precautions for Disassembly	Wear protective equipment (goggles, gloves, etc.)

Safety warning sign:



## 2.2.16 Front Side Door Quarter Window Assembly

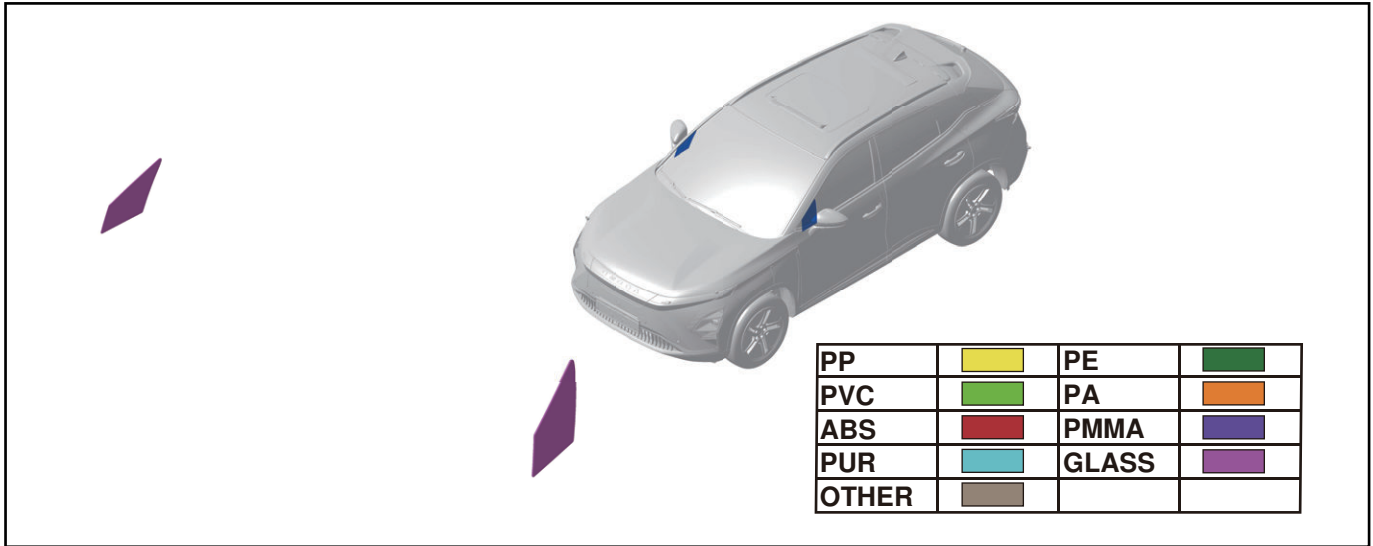

Front side door quarter window assembly:

Applicable Model	T19C EV
Position Description	Front part of front left/right door
Quantity	2
Weight (Kg)	0.29/pc
Main Material	Glass
Fastener	-
Number of Fasteners	-
Disassembly Tool	-
Disassembly Method	Disassemble after disconnecting the connection
Recycling Pathways	Tempered glass foam molding technology
Precautions for Disassembly	Wear protective equipment (goggles, gloves, etc.)

Safety warning sign:

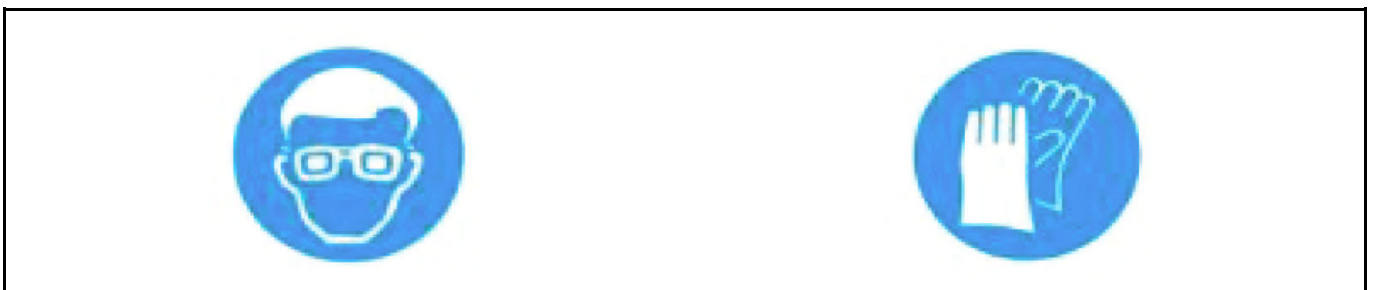

## 2.2.17 Rear Quadrangular Block Assembly

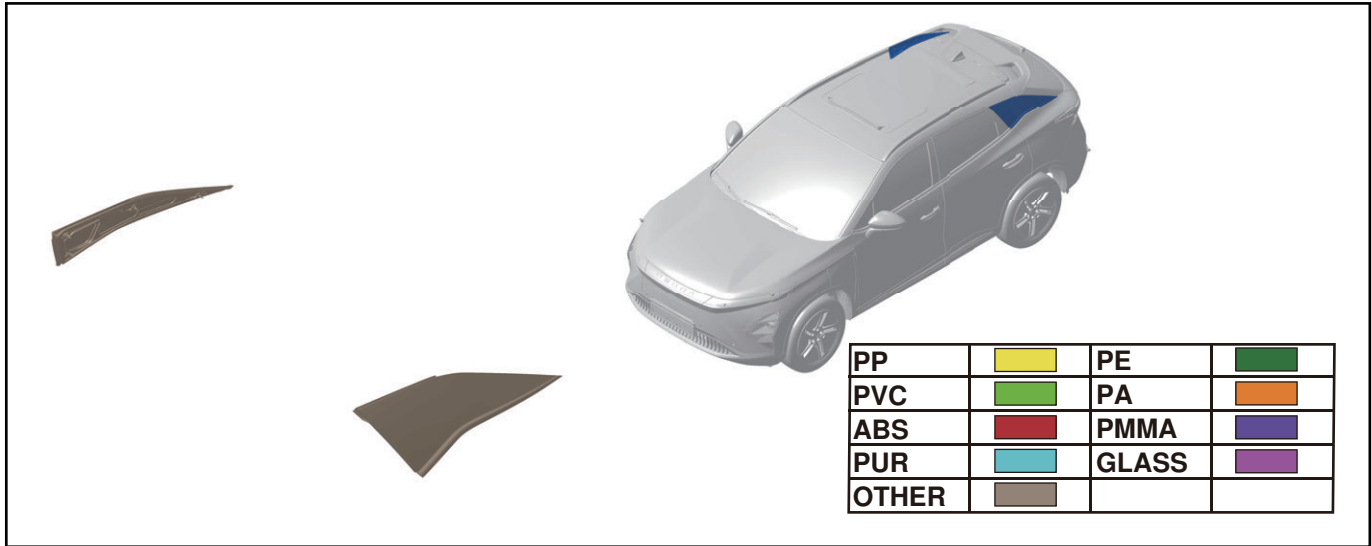

Rear quadrangular block assembly:

Applicable Model	T19C EV
Position Description	Both sides of the rear seat
Quantity	2
Weight (Kg)	0.6/pc
Main Material	PMMA+ASA, ABS
Fastener	Clip
Number of Fasteners	4
Disassembly Tool	Clip remover
Disassembly Method	Using the plastic crow plate to pry off the clip
Recycling Pathways	Modified recycling of waste plastics; recycling of mixed plastics through crushing and separation
Precautions for Disassembly	Wear protective equipment (goggles, gloves, etc.)

Safety warning sign:



## 2.2.18 Sunroof Glass Assembly

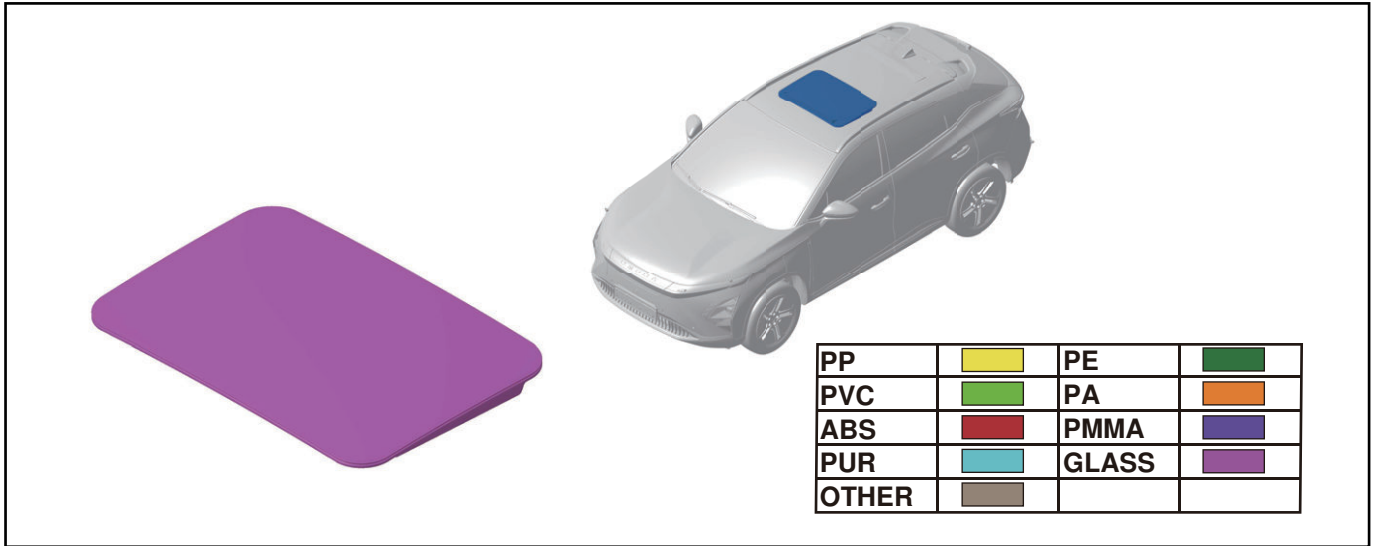

Sliding roof glass assembly:

Applicable Model	T19C EV
Position Description	The middle of roof
Quantity	1
Weight (Kg)	2.16
Main Material	Glass
Fastener	-
Number of Fasteners	-
Disassembly Tool	Windshield removal tool kit
Disassembly Method	Use a windshield removal wire to cut through the adhesive material around the perimeter; disassemble using the windshield removal tool kit
Recycling Pathways	Tempered glass foam molding technology
Precautions for Disassembly	Wear protective equipment (goggles, gloves, etc.)

Safety warning sign:



### 2.2.19 Rear Windshield Assembly

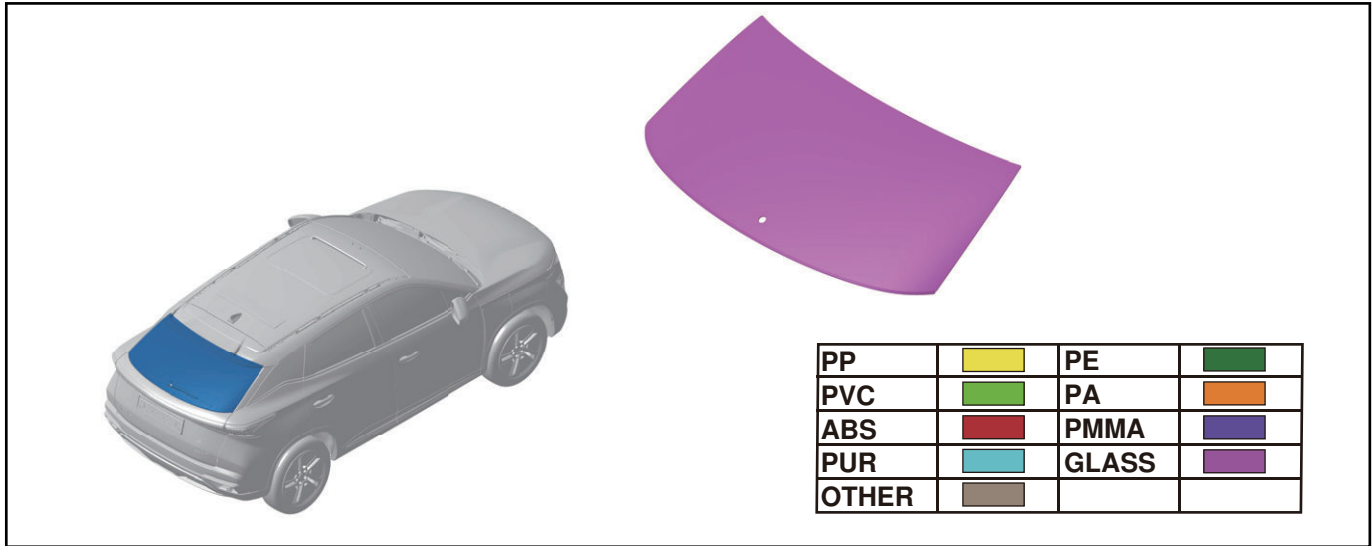

Rear windshield assembly:

Applicable Model	T19C EV
Position Description	On the back door
Quantity	1
Weight (Kg)	5.43
Main Material	Glass
Fastener	-
Number of Fasteners	-
Disassembly Tool	Windshield removal tool kit
Disassembly Method	Use a windshield removal wire to cut through the adhesive material around the perimeter; disassemble using the windshield removal tool kit
Recycling Pathways	Tempered glass foam molding technology
Precautions for Disassembly	Wear protective equipment (goggles, gloves, etc.)

Safety warning sign:



### 2.2.20 Front Compartment Trim Cover Assembly

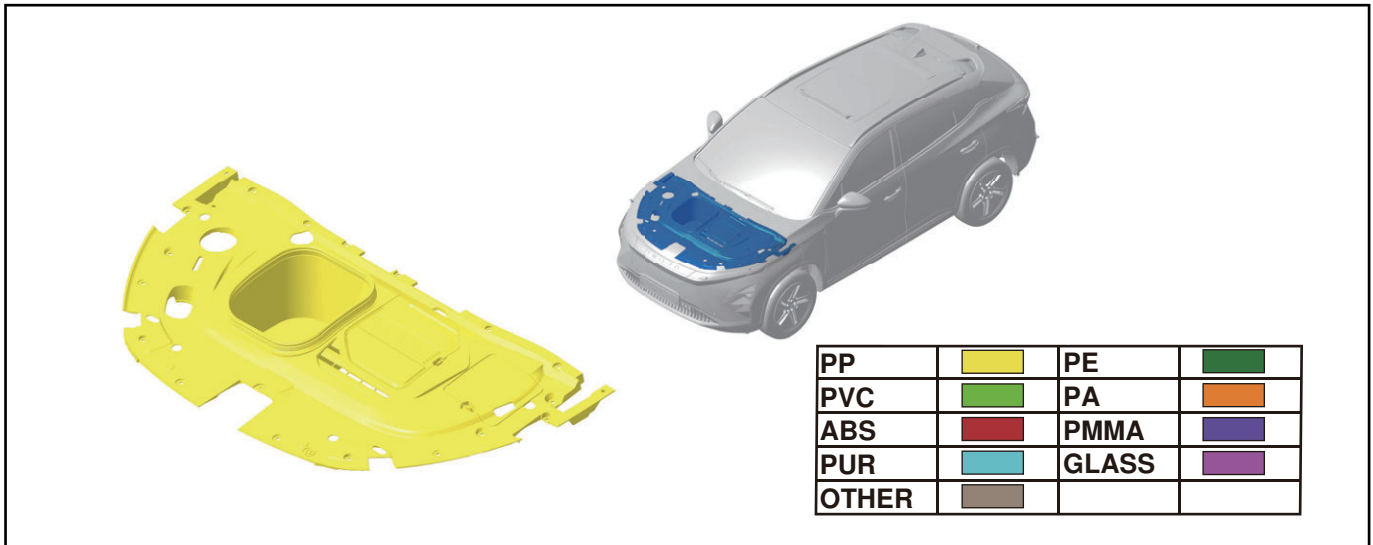

Front compartment trim cover assembly:

Applicable Model	T19C EV
Position Description	In the engine compartment
Quantity	1
Weight (Kg)	4.43
Main Material	PP-T20
Fastener	Clip
Number of Fasteners	21
Disassembly Tool	Clip remover
Disassembly Method	Loosen the fasteners for disassembly
Recycling Pathways	Modified recycling of waste plastics
Precautions for Disassembly	Wear protective equipment (goggles, gloves, etc.)

Safety warning sign:



## 2.2.21 Front Bumper Lower Spoiler Assembly

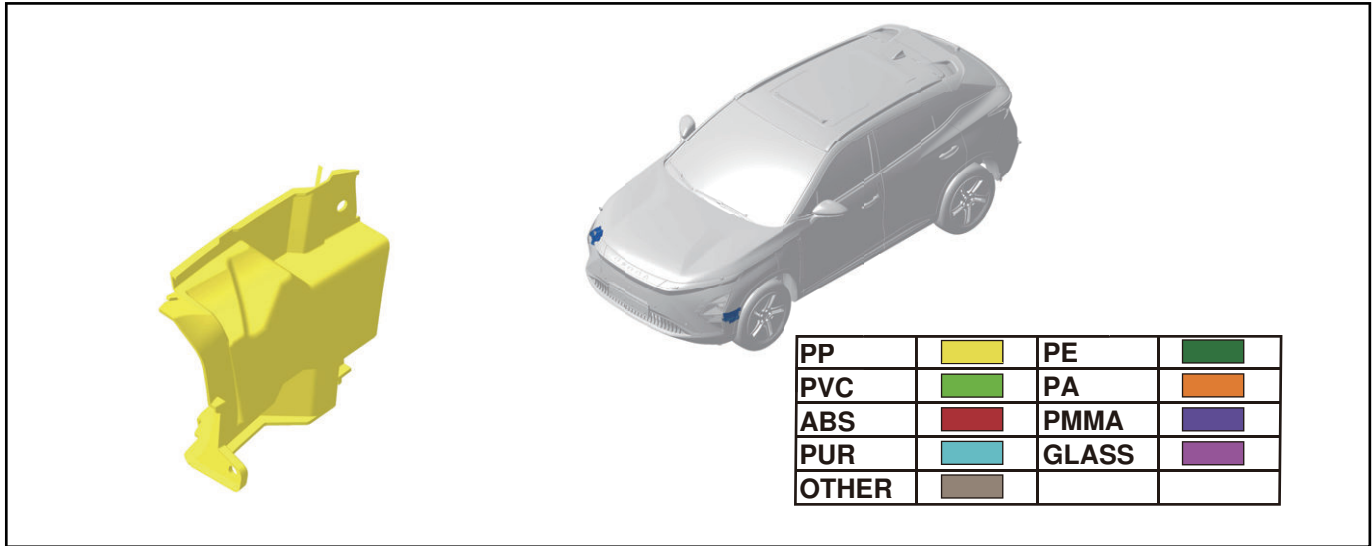

Front bumper lower spoiler assembly:

Applicable Model	T19C EV
Position Description	On the front bumper
Quantity	1
Weight (Kg)	0.5
Main Material	PP+EPDM-T20
Fastener	Screw
Number of Fasteners	8
Disassembly Tool	Cross tip screwdriver
Disassembly Method	Loosen the fasteners for disassembly
Recycling Pathways	Modified recycling of waste plastics
Precautions for Disassembly	Wear protective equipment (goggles, gloves, etc.)

Safety warning sign:



## 2.2.22 Front Bumper Lower Protector Assembly

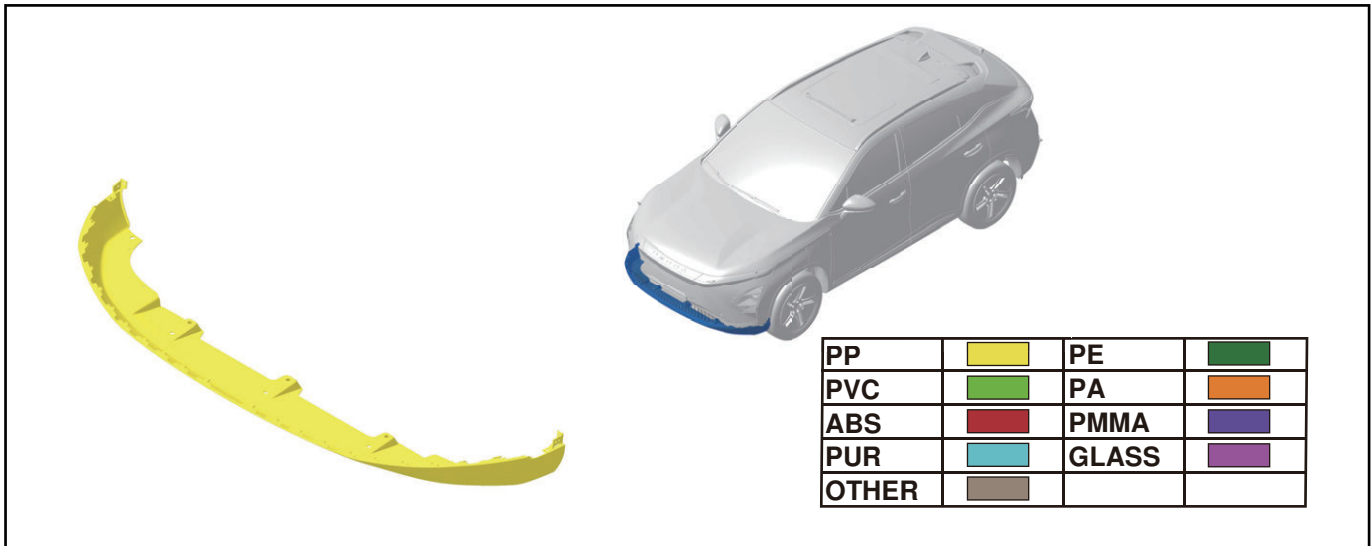

Front bumper lower protector assembly:

Applicable Model	T19C EV
Position Description	On the front bumper
Quantity	1
Weight (Kg)	2.1
Main Material	PP+EPDM-T20
Fastener	Screw
Number of Fasteners	6
Disassembly Tool	Cross tip screwdriver
Disassembly Method	Loosen the fasteners for disassembly
Recycling Pathways	Modified recycling of waste plastics
Precautions for Disassembly	Wear protective equipment (goggles, gloves, etc.)

Safety warning sign:



### 2.2.23 Front Hood Sound Insulator Pad

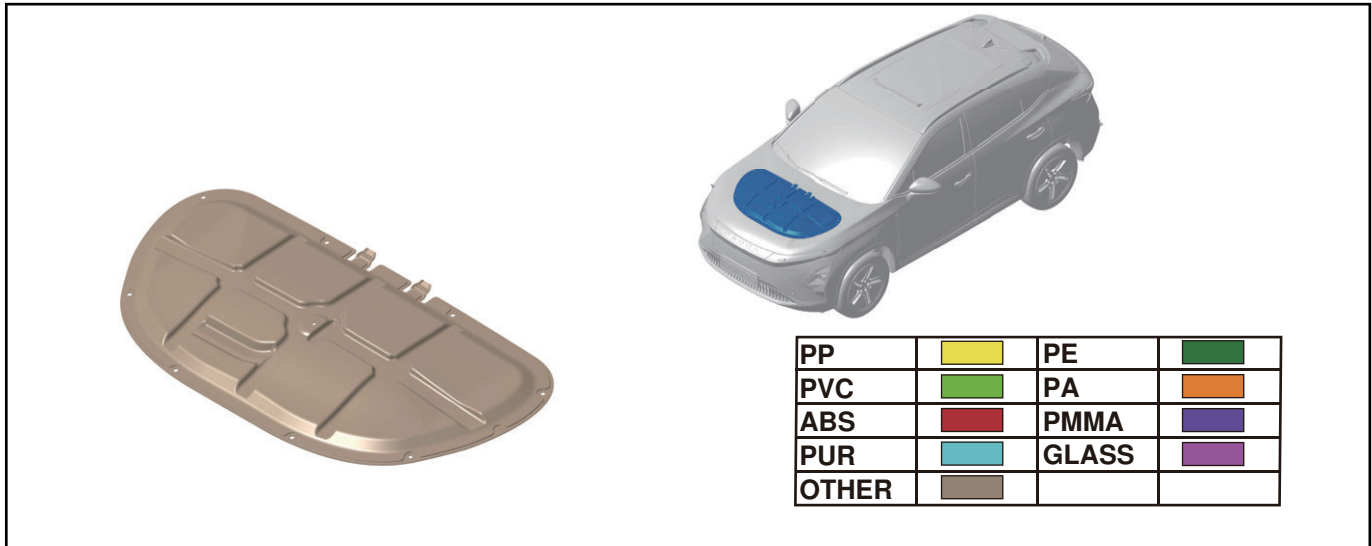

Front hood sound insulator pad:

Applicable Model	T19C EV
Position Description	Above the motor
Quantity	1
Weight (Kg)	0.8
Main Material	Glass fiber
Fastener	Clip
Number of Fasteners	9
Disassembly Tool	Clip remover
Disassembly Method	Loosen the fasteners for disassembly
Recycling Pathways	Modified recycling of waste plastics
Precautions for Disassembly	Wear protective equipment (goggles, gloves, etc.)

Safety warning sign:



### 2.2.24 Cooling Fan Assembly

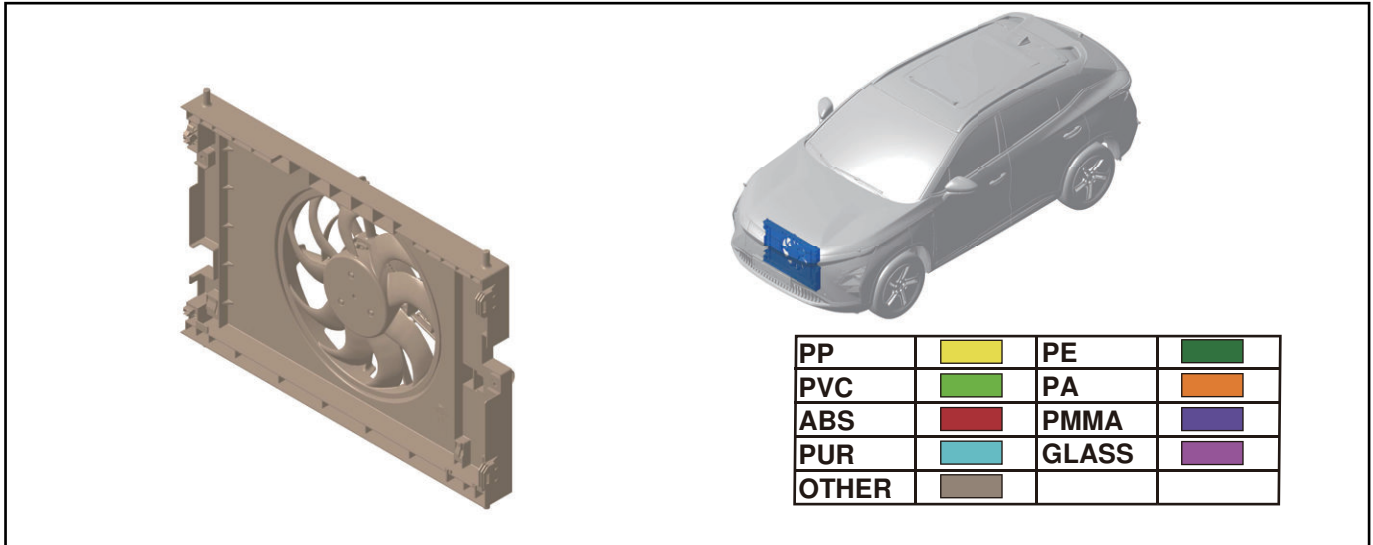

Cooling fan assembly:

Applicable Model	T19C EV
Position Description	In the engine compartment
Quantity	1
Weight (Kg)	4.2
Main Material	PA6-GF30, PA66 GF30, B50A470
Fastener	Bolt
Number of Fasteners	4
Disassembly Tool	Socket wrench
Disassembly Method	Loosen the fasteners for disassembly
Recycling Pathways	Modified recycling of waste plastics
Precautions for Disassembly	Wear protective equipment (goggles, gloves, etc.)

Safety warning sign:



## 2.2.25 Motor Inlet Pipe

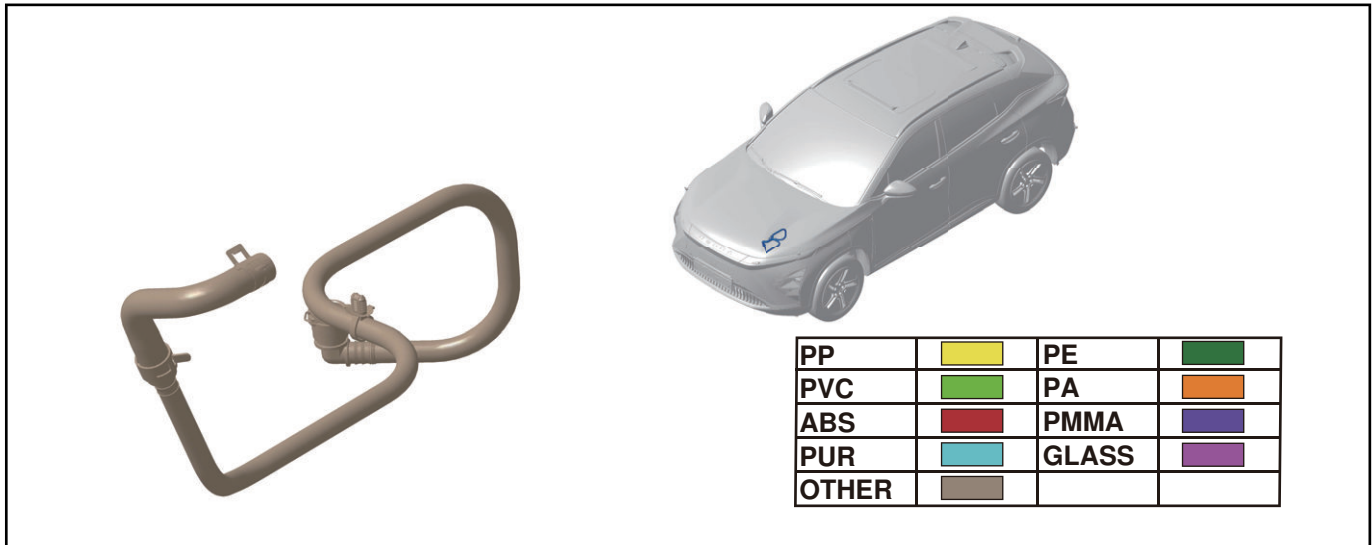

Motor inlet pipe:

Applicable Model	T19C EV
Position Description	In the engine compartment
Quantity	1
Weight (Kg)	0.2
Main Material	EPDM, PA12
Fastener	Clamp, clip, pipe clamp
Number of Fasteners	4
Disassembly Tool	Clamp plier, clip remover
Disassembly Method	Loosen the fasteners for disassembly
Recycling Pathways	Reuse of reclaimed rubber from waste rubber; modified recycling of waste plastics
Precautions for Disassembly	Wear protective equipment (goggles, gloves, etc.)

Safety warning sign:



### 2.2.26 Front Compartment Fuse and Relay Box Assembly

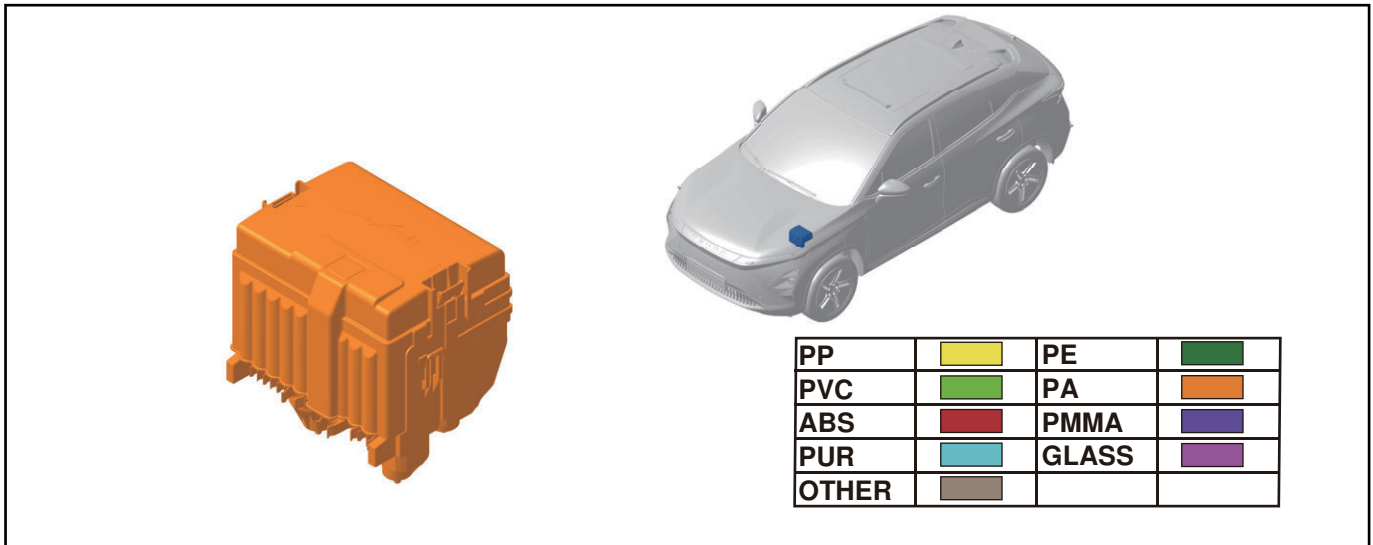

Front compartment fuse and relay box assembly:

Applicable Model	T19C EV
Position Description	In the engine compartment
Quantity	1
Weight (Kg)	1.34
Main Material	PA66-M30
Fastener	Nut
Number of Fasteners	5
Disassembly Tool	Socket wrench
Disassembly Method	Loosen the fasteners for disassembly
Recycling Pathways	Modified recycling of waste plastics
Precautions for Disassembly	Wear protective equipment (goggles, gloves, etc.)

Safety warning sign:



## 2.2.27 A-pillar Lower Trim Panel

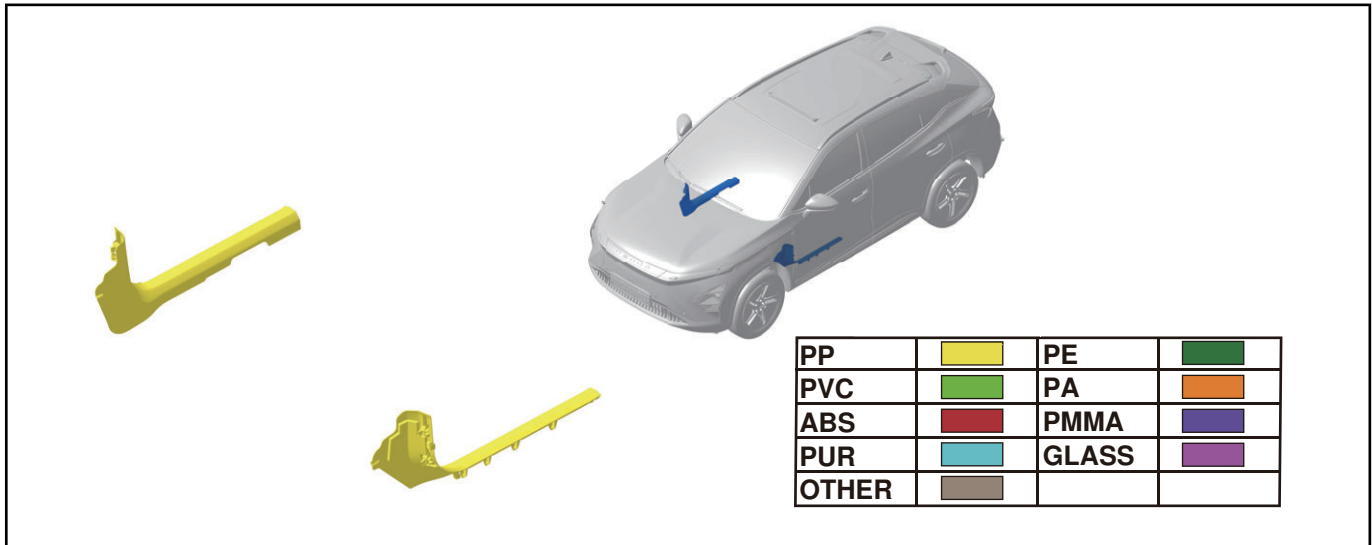

A-pillar lower trim panel:

Applicable Model	T19C EV
Position Description	Under the A-pillar
Quantity	1 on each side
Weight (Kg)	0.3/pc
Main Material	PP+PE-T5
Fastener	Clip
Number of Fasteners	16
Disassembly Tool	Clip remover
Disassembly Method	Loosen the fasteners for disassembly
Recycling Pathways	Modified recycling of waste plastics
Precautions for Disassembly	Wear protective equipment (goggles, gloves, etc.)

Safety warning sign:



### 2.2.28 A-pillar Upper Trim Panel

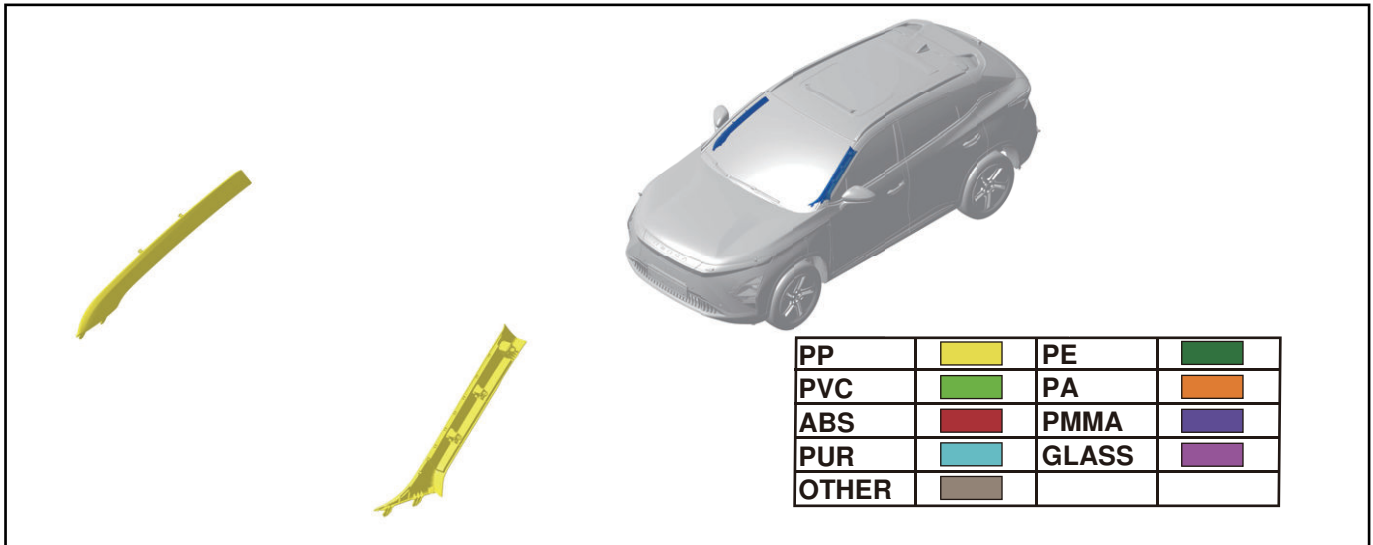

A-pillar upper trim panel:

Applicable Model	T19C EV
Position Description	On the A-pillar
Quantity	1 on each side
Weight (Kg)	0.29/pc
Main Material	PP+EPDM-TD20
Fastener	Clip
Number of Fasteners	6
Disassembly Tool	Clip remover
Disassembly Method	Loosen the fasteners for disassembly
Recycling Pathways	Modified recycling of waste plastics
Precautions for Disassembly	Wear protective equipment (goggles, gloves, etc.)

Safety warning sign:



## 2.2.29 B-pillar Upper Trim Panel

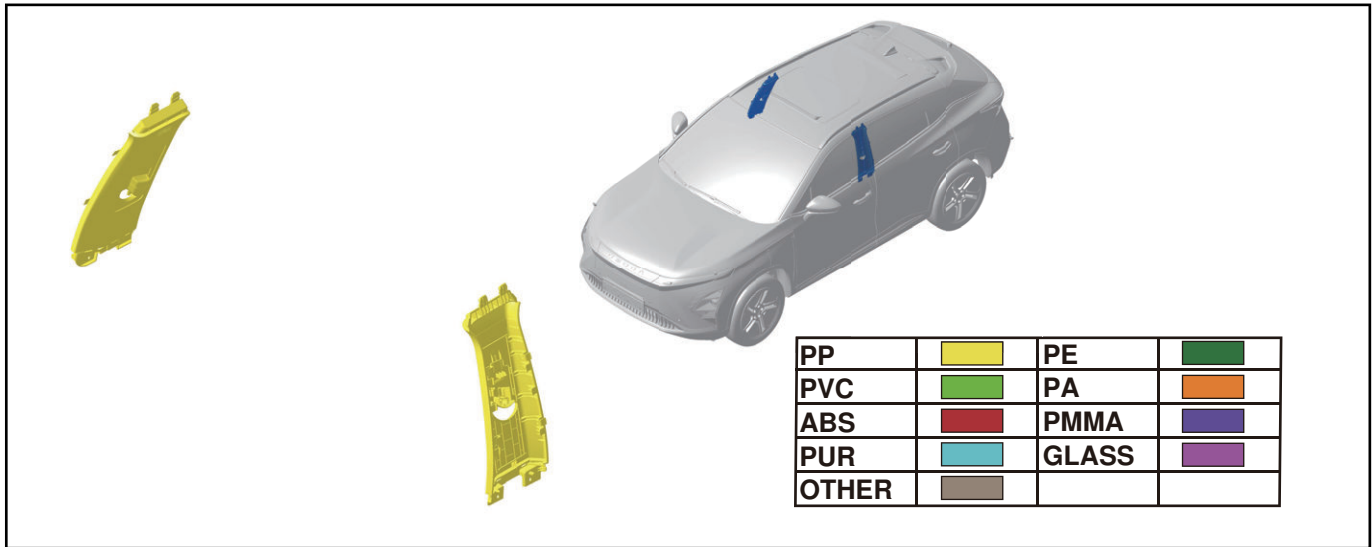

B-pillar upper trim panel:

Applicable Model	T19C EV
Position Description	On the B-pillar
Quantity	1 on each side
Weight (Kg)	0.43/pc
Main Material	PP+EPDM-T20
Fastener	Clip
Number of Fasteners	28
Disassembly Tool	Clip remover
Disassembly Method	Loosen the fasteners for disassembly
Recycling Pathways	Modified recycling of waste plastics
Precautions for Disassembly	Wear protective equipment (goggles, gloves, etc.)

Safety warning sign:

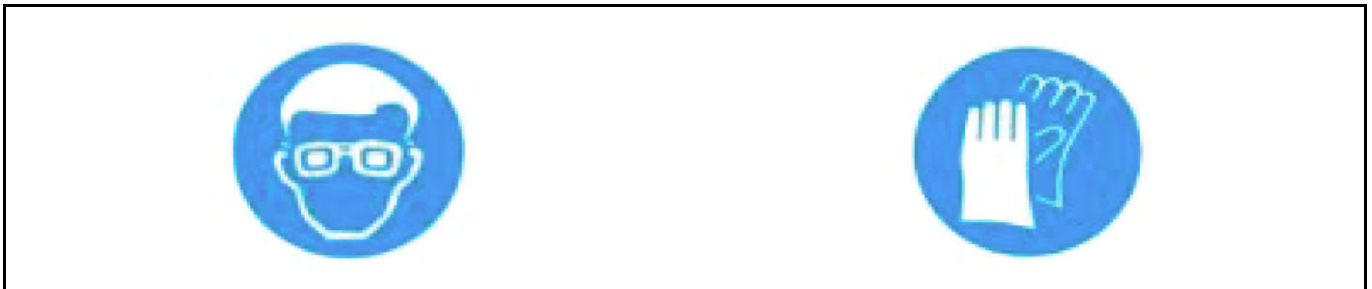

### 2.2.30 B-pillar Lower Trim Panel

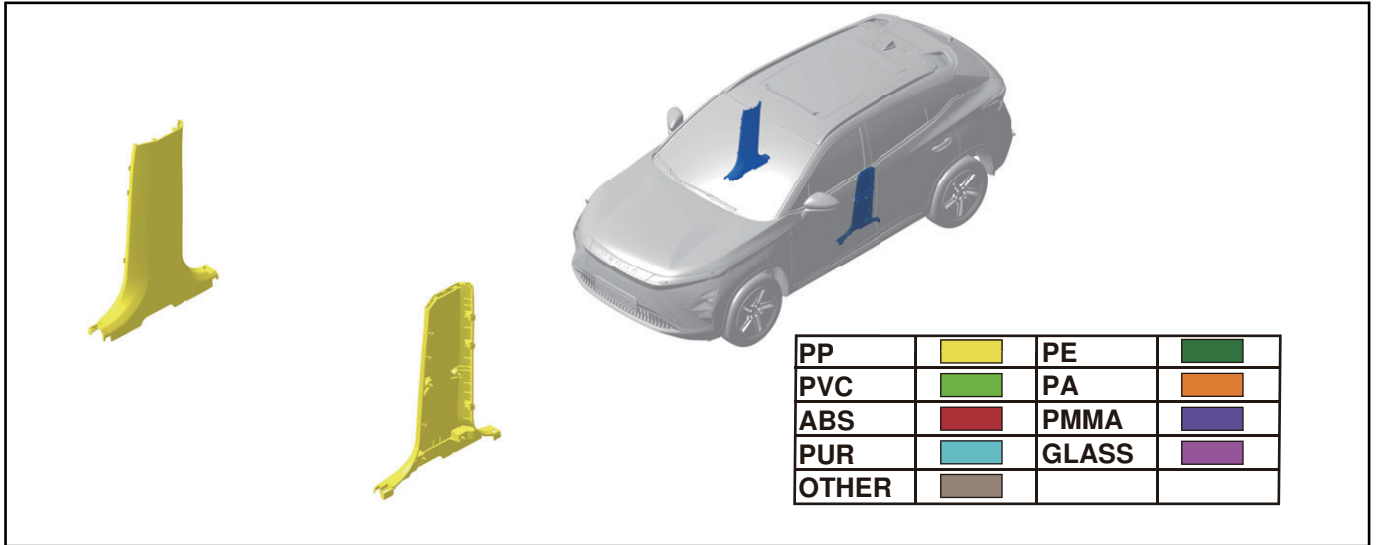

B-pillar lower trim panel:

Applicable Model	T19C EV
Position Description	On the B-pillar
Quantity	1 on each side
Weight (Kg)	0.58/pc
Main Material	PP+PE-T5
Fastener	Clip
Number of Fasteners	20
Disassembly Tool	Clip remover
Disassembly Method	Loosen the fasteners for disassembly
Recycling Pathways	Modified recycling of waste plastics
Precautions for Disassembly	Wear protective equipment (goggles, gloves, etc.)

Safety warning sign:



## 2.2.31 C-pillar Trim Panel

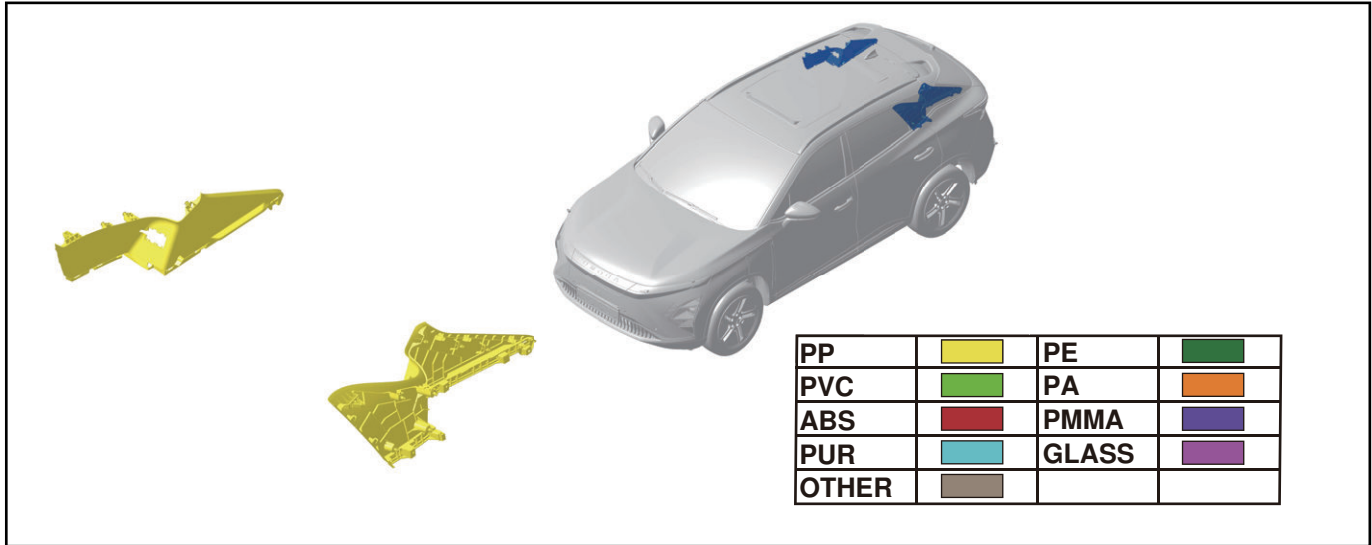

C-pillar trim panel:

Applicable Model	T19C EV
Position Description	On the C-pillar
Quantity	1 on each side
Weight (Kg)	0.63/pc
Main Material	PP+EPDM-TD20
Fastener	Screw, clip
Number of Fasteners	20
Disassembly Tool	Cross tip screwdriver, clip remover
Disassembly Method	Loosen the fasteners for disassembly
Recycling Pathways	Modified recycling of waste plastics
Precautions for Disassembly	Wear protective equipment (goggles, gloves, etc.)

Safety warning sign:

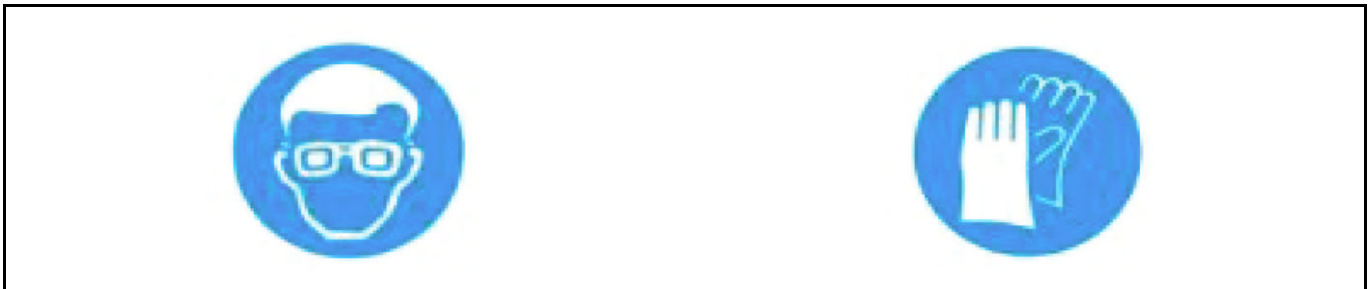

### 2.2.32 C-pillar Lower Trim Panel

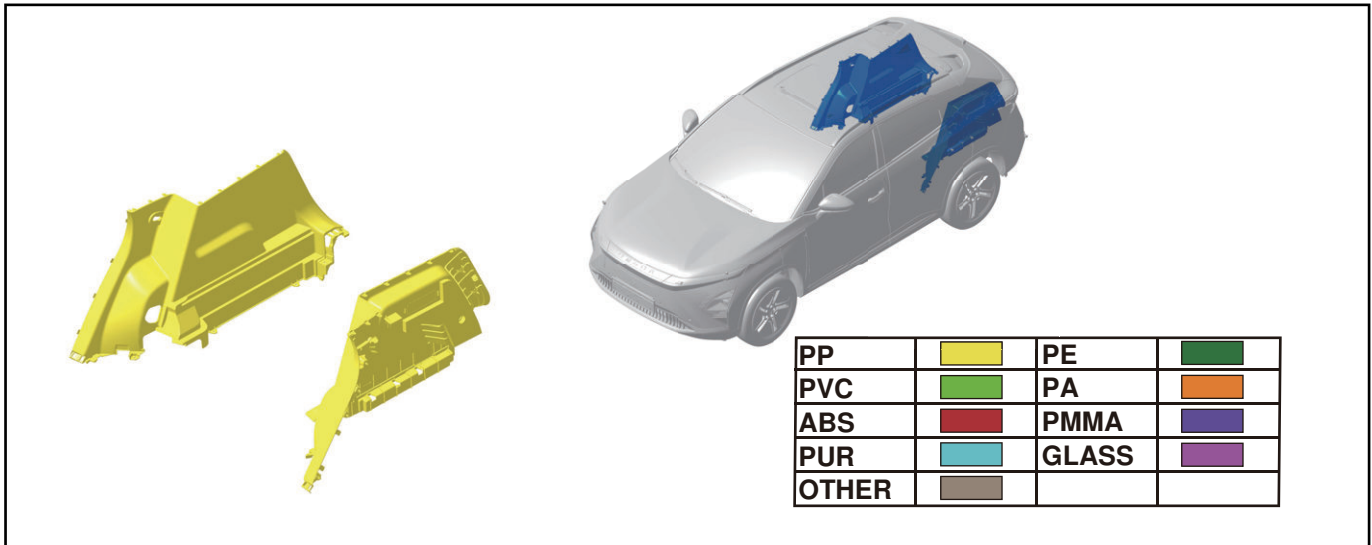

C-pillar lower trim panel:

Applicable Model	T19C EV
Position Description	On the C-pillar
Quantity	1 on each side
Weight (Kg)	1.98/pc
Main Material	PP+PE-T5
Fastener	Screw, clip
Number of Fasteners	34
Disassembly Tool	Cross tip screwdriver, clip remover
Disassembly Method	Loosen the fasteners for disassembly
Recycling Pathways	Modified recycling of waste plastics
Precautions for Disassembly	Wear protective equipment (goggles, gloves, etc.)

Safety warning sign:



### 2.2.33 Rear Doorsill Pressure Plate Assembly

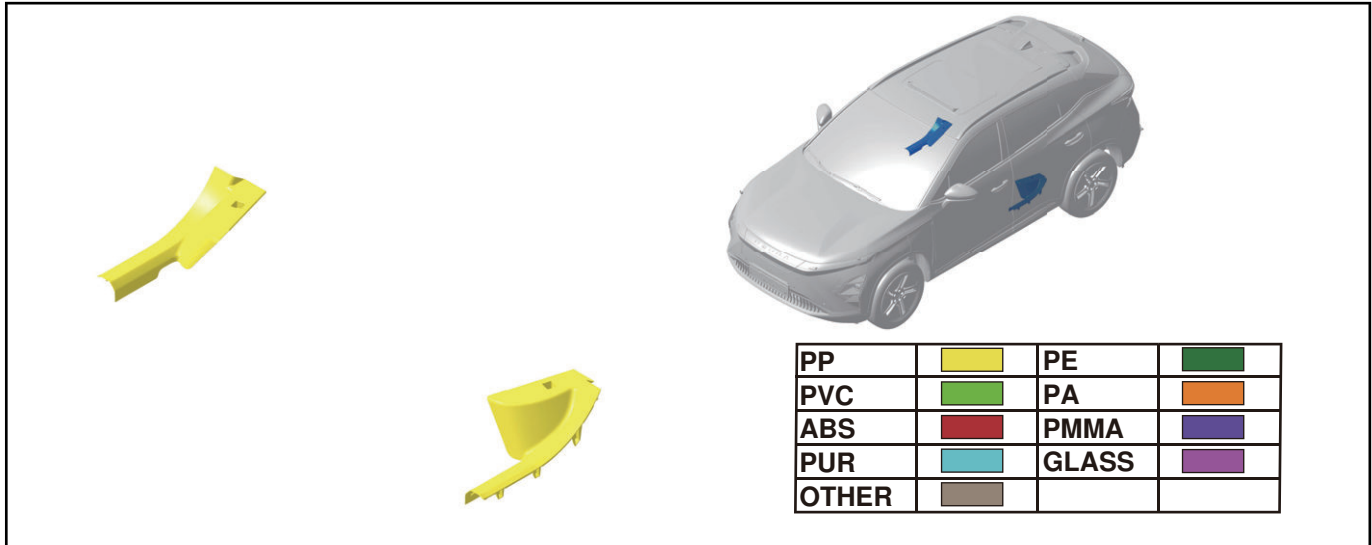

Rear doorsill pressure plate assembly:

Applicable Model	T19C EV
Position Description	Under the rear door
Quantity	1 on each side
Weight (Kg)	0.2/pc
Main Material	PP+PE-T5
Fastener	Screw, clip
Number of Fasteners	14
Disassembly Tool	Cross tip screwdriver, clip remover
Disassembly Method	Loosen the fasteners for disassembly
Recycling Pathways	Modified recycling of waste plastics
Precautions for Disassembly	Wear protective equipment (goggles, gloves, etc.)

Safety warning sign:



### 2.2.34 Front Chassis Protector

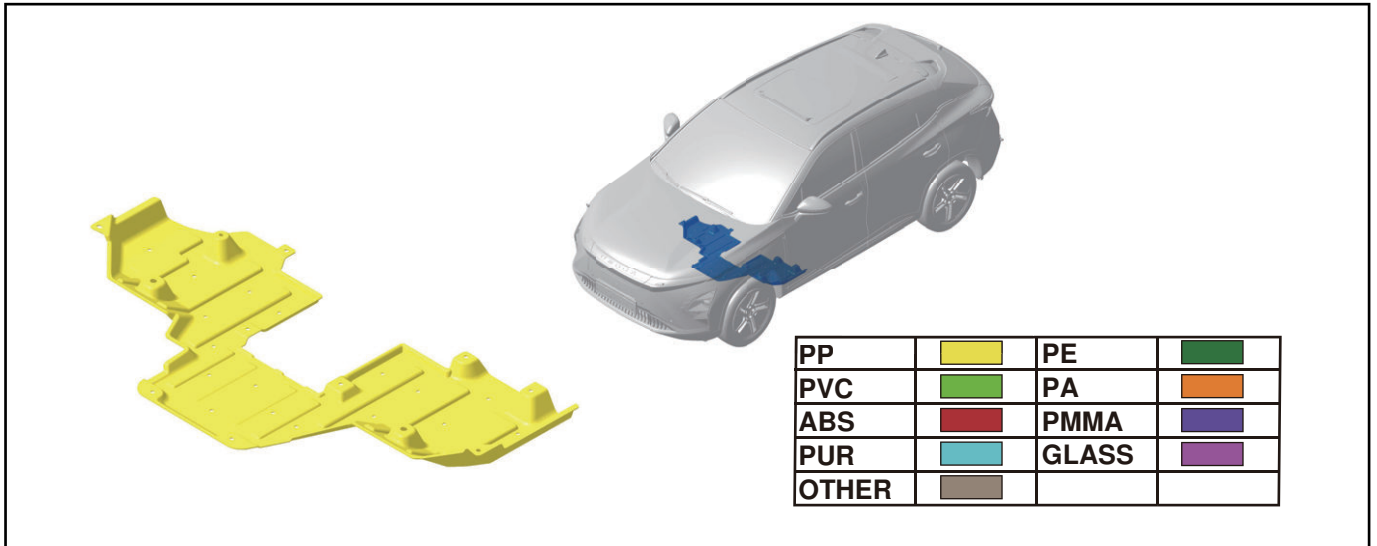

Front chassis protector:

Applicable Model	T19C EV
Position Description	Underbody
Quantity	1
Weight (Kg)	1.03
Main Material	PP, PE, PET
Fastener	Bolt, clip
Number of Fasteners	12
Disassembly Tool	Socket wrench, clip remover
Disassembly Method	Loosen the fasteners for disassembly
Recycling Pathways	Modified recycling of waste plastics
Precautions for Disassembly	Wear protective equipment (goggles, gloves, etc.)

Safety warning sign:



### 2.2.35 Front Doorsill Trim Panel

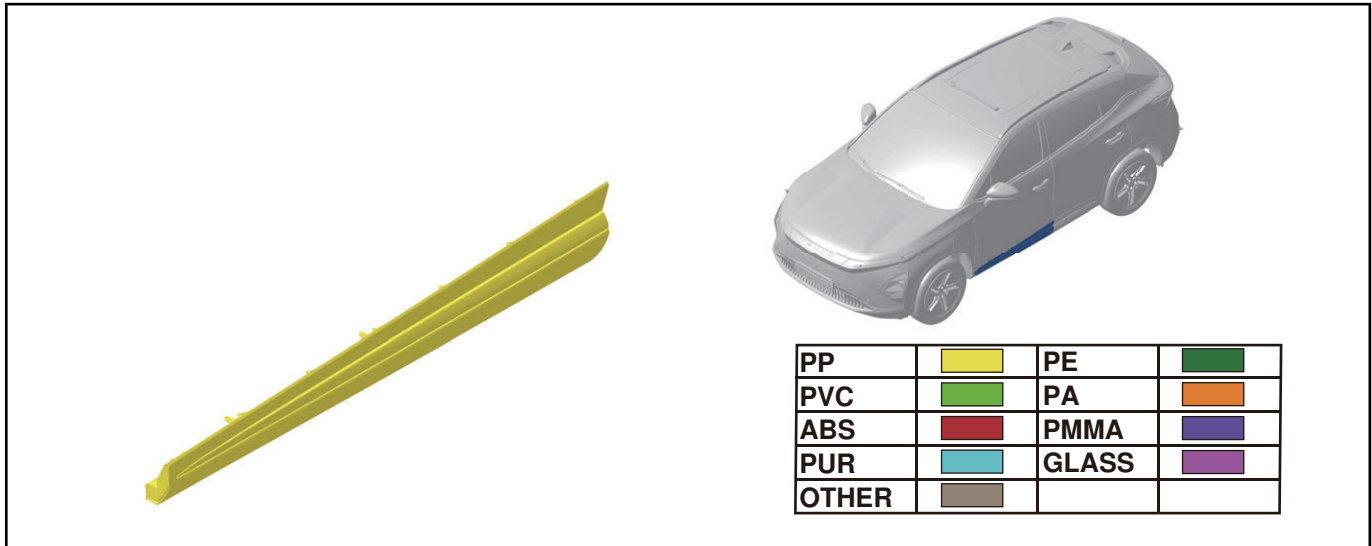

Front doorsill trim panel:

Applicable Model	T19C EV
Position Description	Under the front door
Quantity	1 on each side
Weight (Kg)	0.97/pc
Main Material	PP+EPDM-T20
Fastener	Screw, clip
Number of Fasteners	34
Disassembly Tool	Cross tip screwdriver, clip remover
Disassembly Method	Loosen the fasteners for disassembly
Recycling Pathways	Modified recycling of waste plastics
Precautions for Disassembly	Wear protective equipment (goggles, gloves, etc.)

Safety warning sign:



### 2.2.36 Rear Doorsill Trim Panel

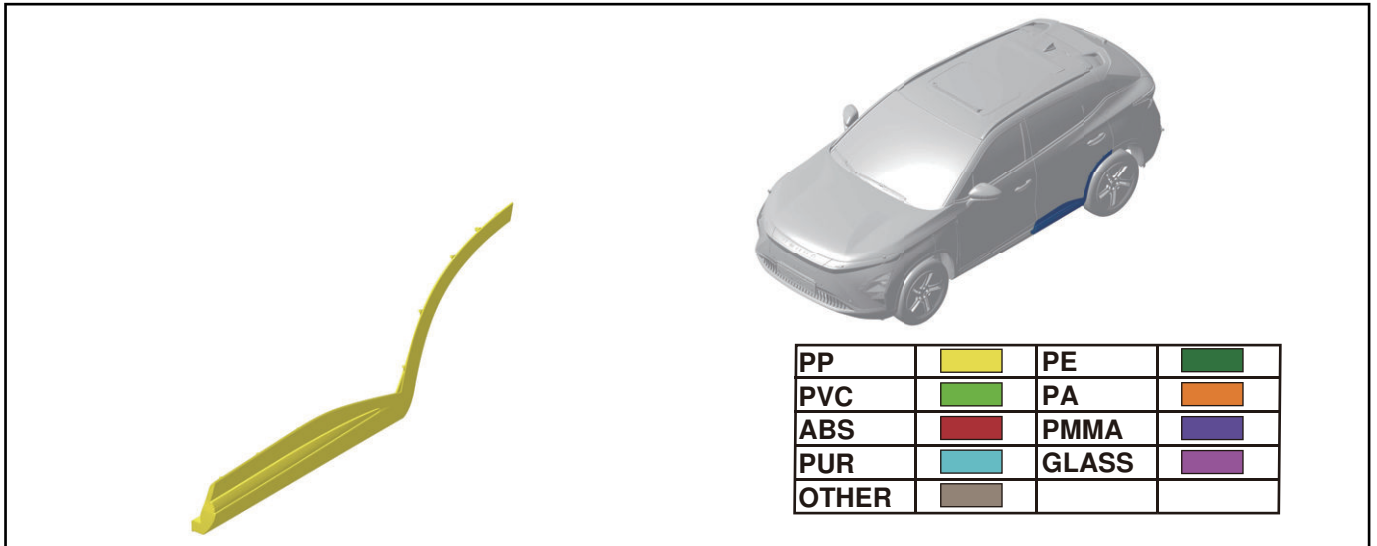

Rear doorsill trim panel:

Applicable Model	T19C EV
Position Description	Under the rear door
Quantity	1 on each side
Weight (Kg)	0.99/pc
Main Material	PP+EPDM-T20
Fastener	Screw, clip
Number of Fasteners	28
Disassembly Tool	Cross tip screwdriver, clip remover
Disassembly Method	Loosen the fasteners for disassembly
Recycling Pathways	Modified recycling of waste plastics
Precautions for Disassembly	Wear protective equipment (goggles, gloves, etc.)

Safety warning sign:



## 2.2.37 Back Doorsill Trim Panel

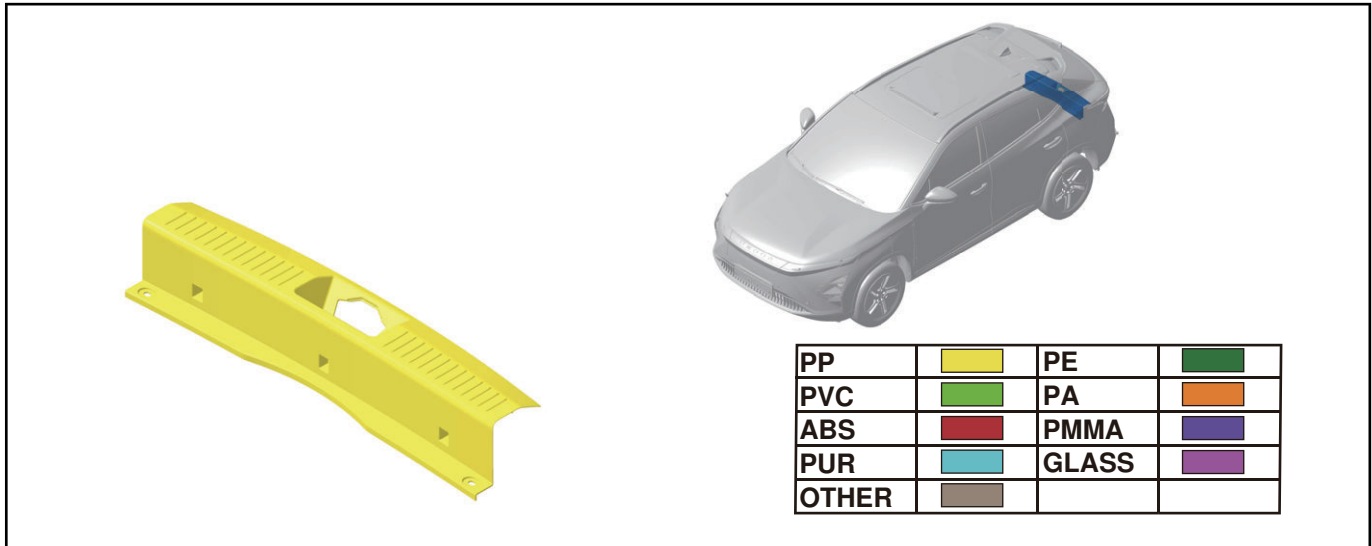

Back doorsill trim panel:

Applicable Model	T19C EV
Position Description	Under the back door
Quantity	1
Weight (Kg)	0.6
Main Material	PP+PE-T5
Fastener	Screw, clip
Number of Fasteners	9
Disassembly Tool	Cross tip screwdriver, clip remover
Disassembly Method	Loosen the fasteners for disassembly
Recycling Pathways	Modified recycling of waste plastics
Precautions for Disassembly	Wear protective equipment (goggles, gloves, etc.)

Safety warning sign:



### 2.2.38 Instrument Panel End Plate

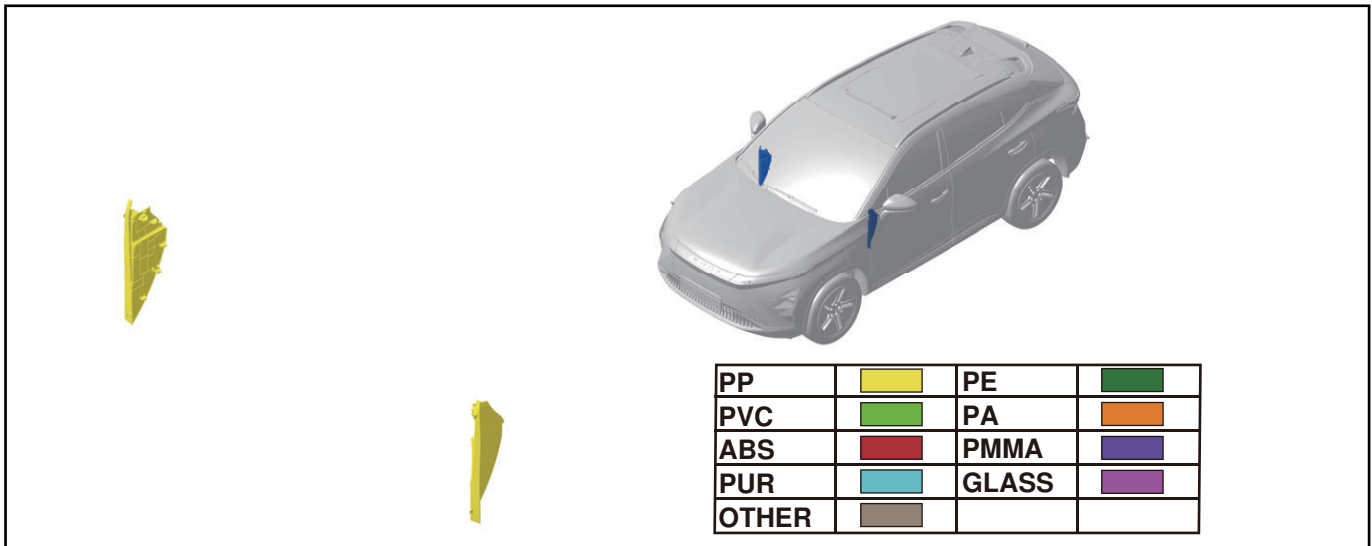

Instrument panel end plate:

Applicable Model	T19C EV
Position Description	Located at both ends of instrument panel
Quantity	2
Weight (Kg)	0.14/pc
Main Material	PP+EPDM-T20
Fastener	Clip
Number of Fasteners	10
Disassembly Tool	No
Disassembly Method	Remove directly
Recycling Pathways	Modified recycling of waste plastics
Precautions for Disassembly	Wear protective equipment (goggles, gloves, etc.)

Safety warning sign:



## 2.2.39 Instrument Panel Left Trim Panel

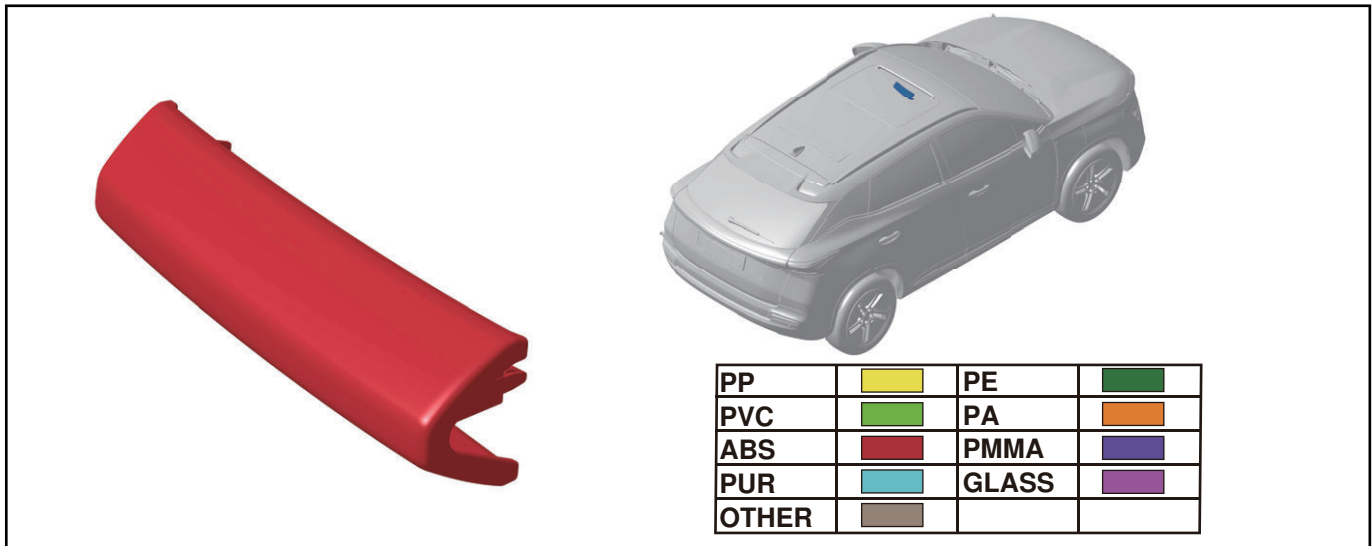

Instrument panel left trim panel:

Applicable Model	T19C EV
Position Description	On the instrument panel
Quantity	1
Weight (Kg)	0.12
Main Material	PC+ABS
Fastener	Clip, screw
Number of Fasteners	3
Disassembly Tool	Flat tip screwdriver
Disassembly Method	Loosen the fastener for disassembly
Recycling Pathways	Modified recycling of waste plastics
Precautions for Disassembly	Wear protective equipment (goggles, gloves, etc.)

Safety warning sign:



### 2.2.40 Instrument Panel Right Trim Panel

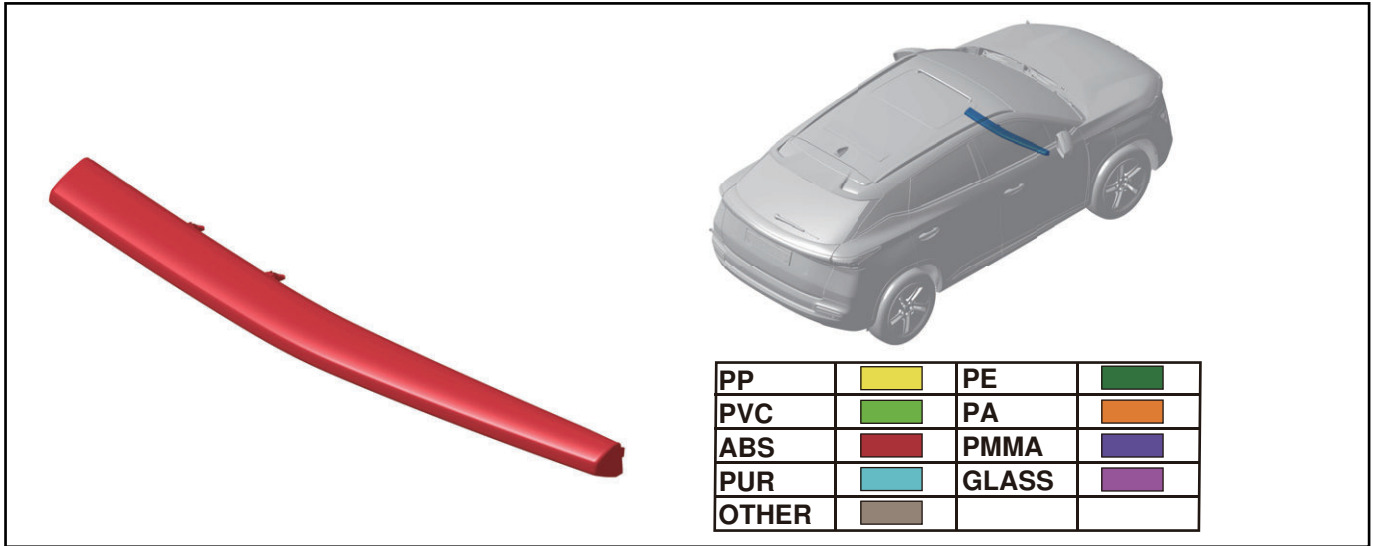

Instrument panel right trim panel:

Applicable Model	T19C EV
Position Description	On the instrument panel
Quantity	1
Weight (Kg)	0.6
Main Material	PC+ABS
Fastener	Clip, screw
Number of Fasteners	12
Disassembly Tool	Flat tip screwdriver
Disassembly Method	Loosen the fastener for disassembly
Recycling Pathways	Modified recycling of waste plastics
Precautions for Disassembly	Wear protective equipment (goggles, gloves, etc.)

Safety warning sign:



### 2.2.41 Sun Visor

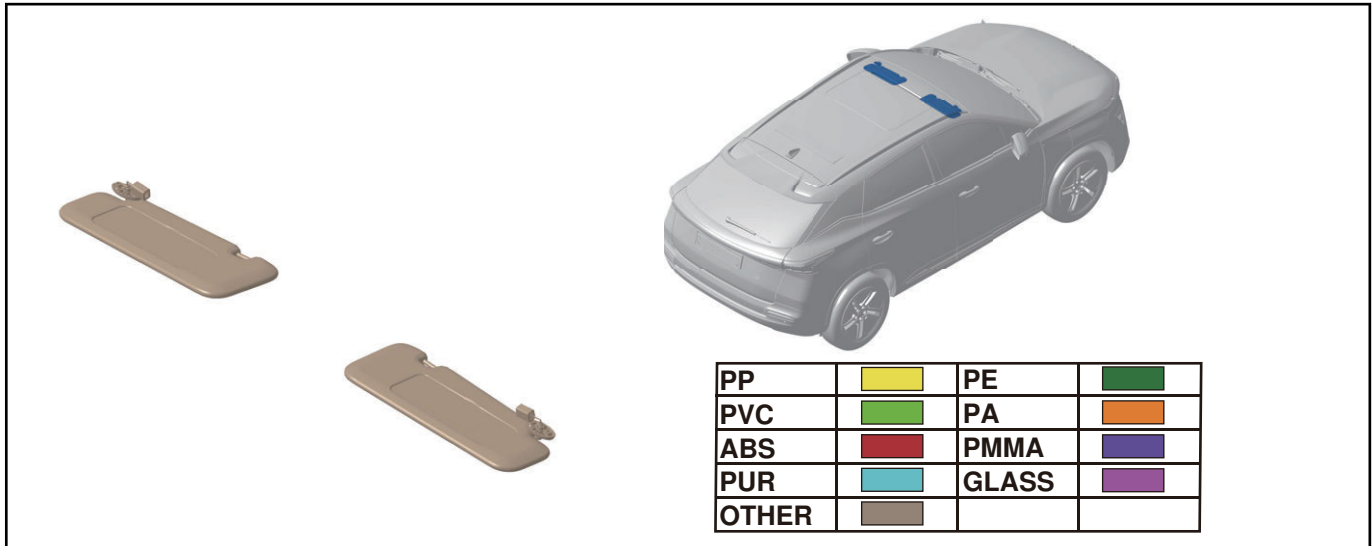

Sun visor:

Applicable Model	T19C EV
Position Description	On the roof
Quantity	1 on each side
Weight (Kg)	0.6/pc
Main Material	PP-T20, glass, knitted fabric, PC+ABS
Fastener	Screw
Number of Fasteners	4
Disassembly Tool	Cross tip screwdriver
Disassembly Method	Loosen the fasteners for disassembly
Recycling Pathways	Modified recycling of waste plastics
Precautions for Disassembly	Wear protective equipment (goggles, gloves, etc.)

Safety warning sign:



### 2.2.42 Inside Rear View Mirror

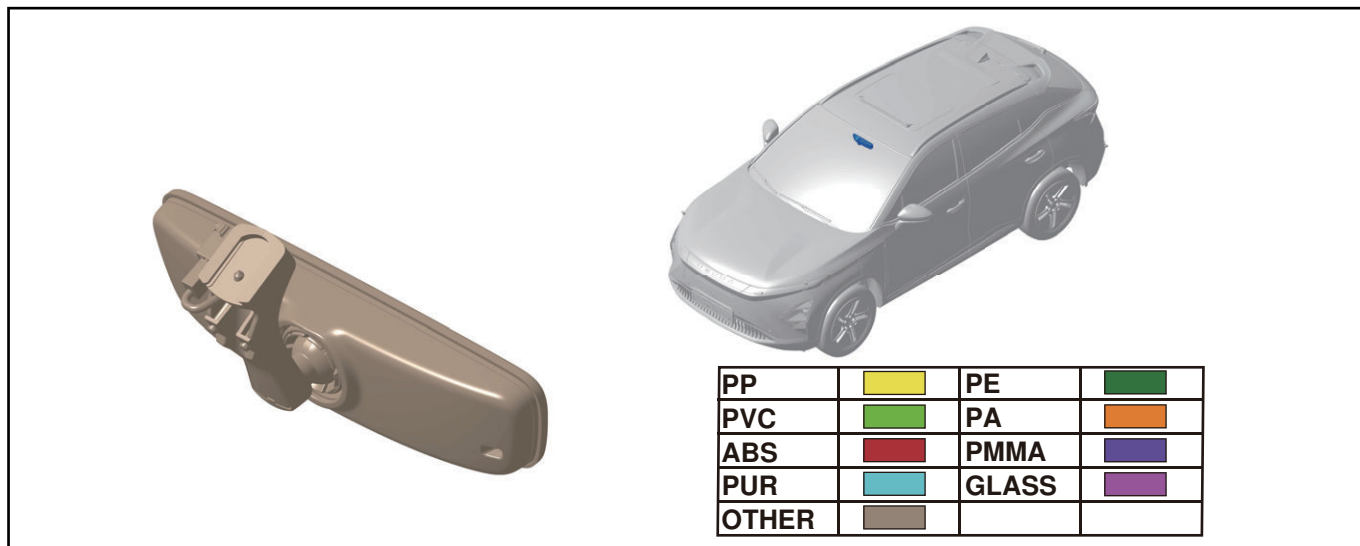

Inside rear view mirror:

Applicable Model	T19C EV
Position Description	On the roof
Quantity	1
Weight (Kg)	0.4
Main Material	Glass, ADC12, PC+ABS
Fastener	Screw
Number of Fasteners	1
Disassembly Tool	Cross tip screwdriver
Disassembly Method	Loosen the fasteners for disassembly
Recycling Pathways	Modified recycling of waste plastics; after preprocessing the recycled glass, it is remelted in a furnace to manufacture glass containers, glass fibers, and other products; melting and reuse of metal materials
Precautions for Disassembly	Wear protective equipment (goggles, gloves, etc.)

Safety warning sign:



### 2.2.43 Front Door Inner Protector

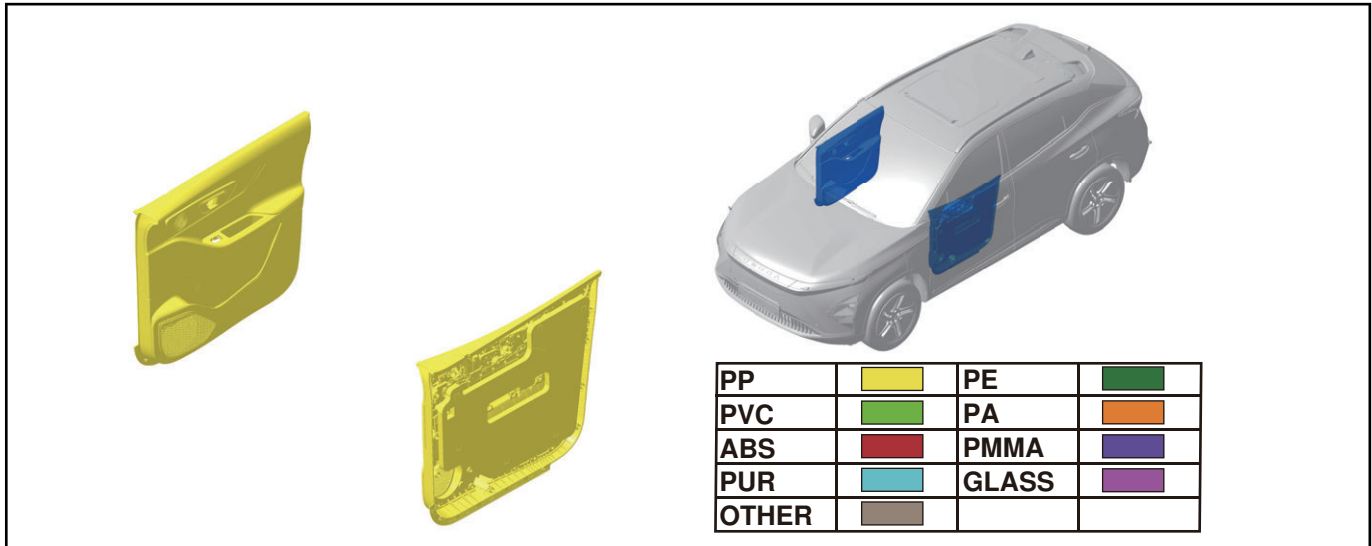

Front door inner protector:

Applicable Model	T19C EV
Position Description	On the front door
Quantity	2
Weight (Kg)	4.2/pc
Main Material	PP, ABS
Fastener	Screw, clip
Number of Fasteners	24
Disassembly Tool	Cross tip screwdriver, clip remover
Disassembly Method	Loosen the fasteners for disassembly
Recycling Pathways	Modified recycling of waste plastics
Precautions for Disassembly	Wear protective equipment (goggles, gloves, etc.)

Safety warning sign:



### 2.2.44 Rear Door Inner Protector

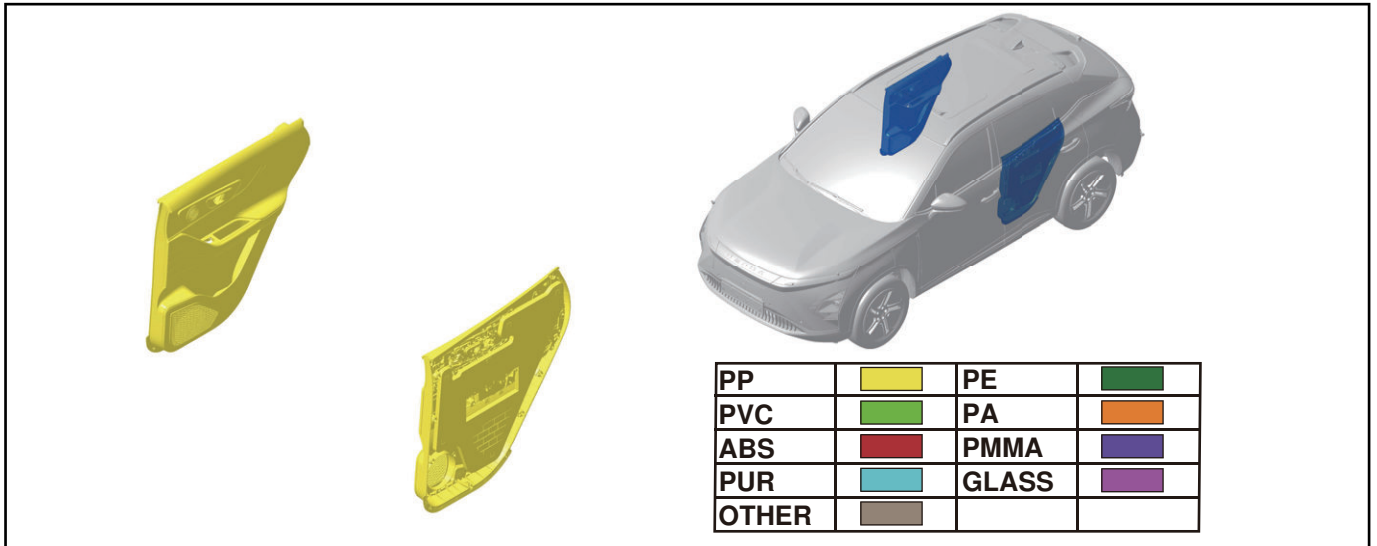

Rear door inner protector:

Applicable Model	T19C EV
Position Description	On the rear door
Quantity	2
Weight (Kg)	3.7/pc
Main Material	PP, ABS
Fastener	Screw, clip
Number of Fasteners	22
Disassembly Tool	Cross tip screwdriver, clip remover
Disassembly Method	Loosen the fasteners for disassembly
Recycling Pathways	Modified recycling of waste plastics
Precautions for Disassembly	Wear protective equipment (goggles, gloves, etc.)

Safety warning sign:



## 2.2.45 Interior Roof

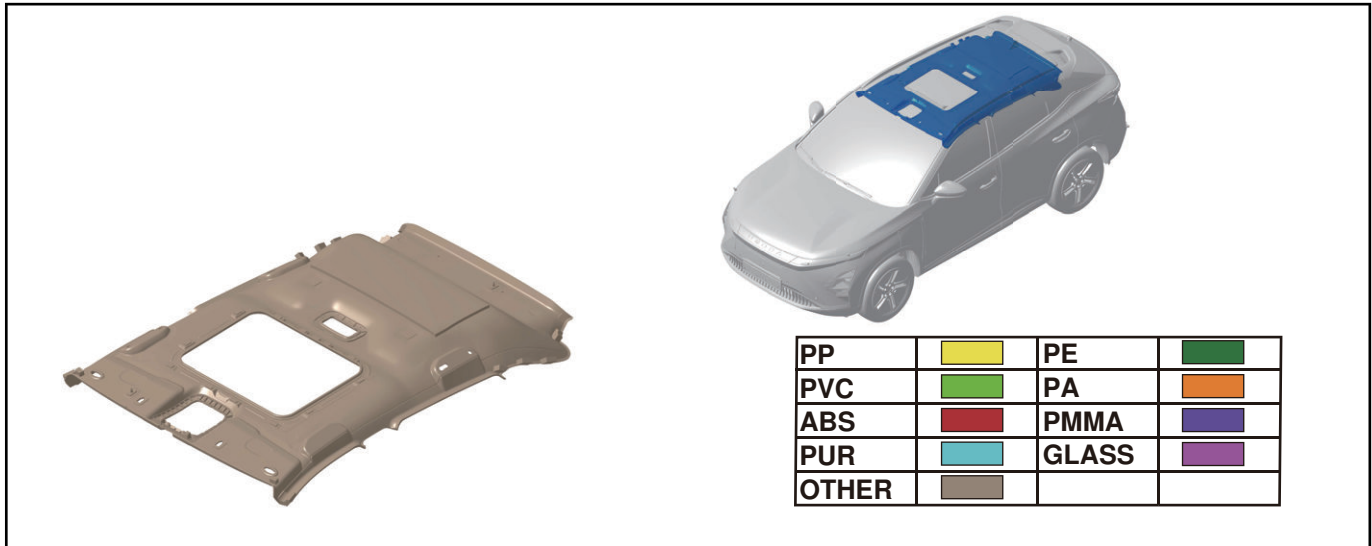

Interior roof:

Applicable Model	T19C EV
Position Description	Top part inside the vehicle
Quantity	1
Weight (Kg)	3.2
Main Material	PU, DC54D+Z, knitted fabric, PU foam, PC+ABS
Fastener	Clip
Number of Fasteners	13
Disassembly Tool	Clip remover
Disassembly Method	Loosen the fasteners for disassembly
Recycling Pathways	Reuse of rigid polyurethane foam through blending modification; melting and reuse of metal materials
Precautions for Disassembly	Wear protective equipment (goggles, gloves, etc.)

Safety warning sign:



### 2.2.46 Front Floor Front Left Carpet Assembly

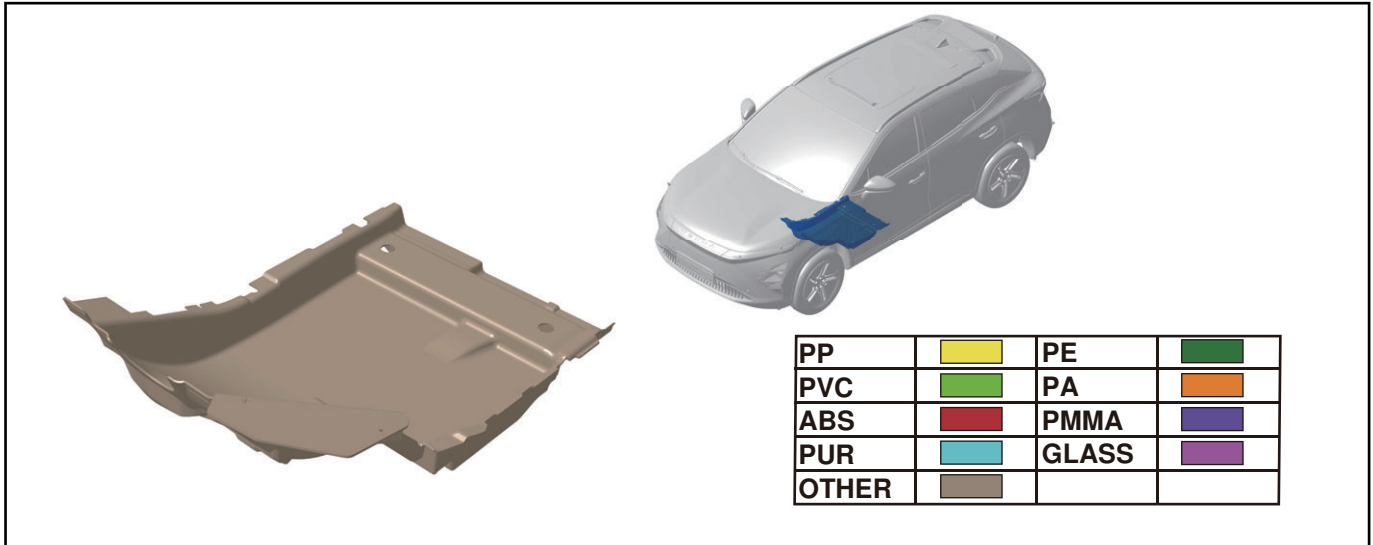

Front floor front left carpet assembly:

Applicable Model	T19C EV
Position Description	Bottom part inside the vehicle
Quantity	1
Weight (Kg)	2.38
Main Material	PU
Fastener	-
Number of Fasteners	-
Disassembly Tool	-
Disassembly Method	Directly remove
Recycling Pathways	Reuse of rigid polyurethane foam through blending modification
Precautions for Disassembly	Wear protective equipment (goggles, gloves, etc.)

Safety warning sign:

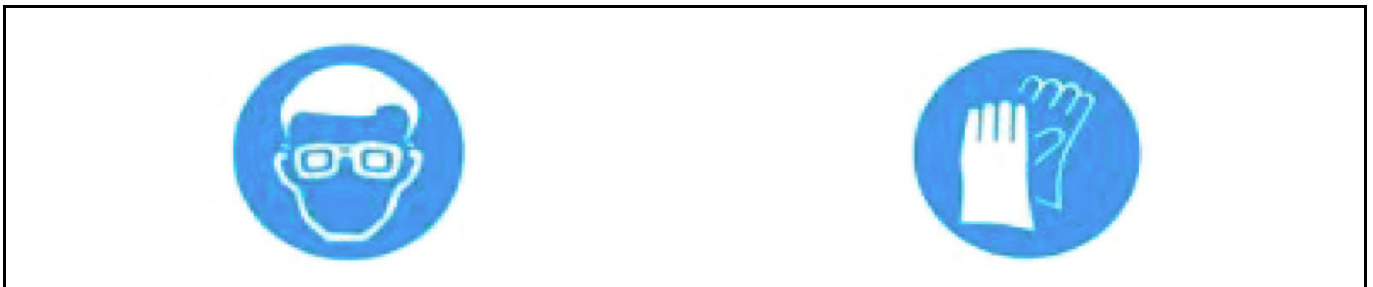

## 2.2.47 Front Floor Front Right Carpet Assembly

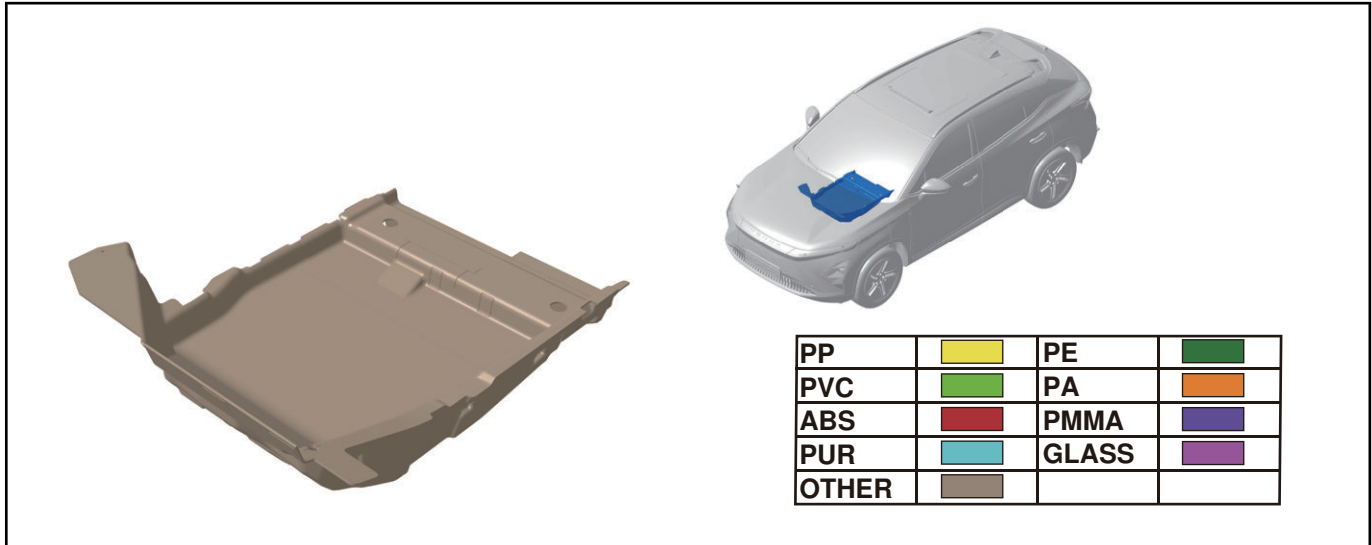

Front floor front right carpet assembly:

Applicable Model	T19C EV
Position Description	Bottom part inside the vehicle
Quantity	1
Weight (Kg)	2.4
Main Material	PU
Fastener	-
Number of Fasteners	-
Disassembly Tool	-
Disassembly Method	Directly remove
Recycling Pathways	Reuse of rigid polyurethane foam through blending modification
Precautions for Disassembly	Wear protective equipment (goggles, gloves, etc.)

Safety warning sign:

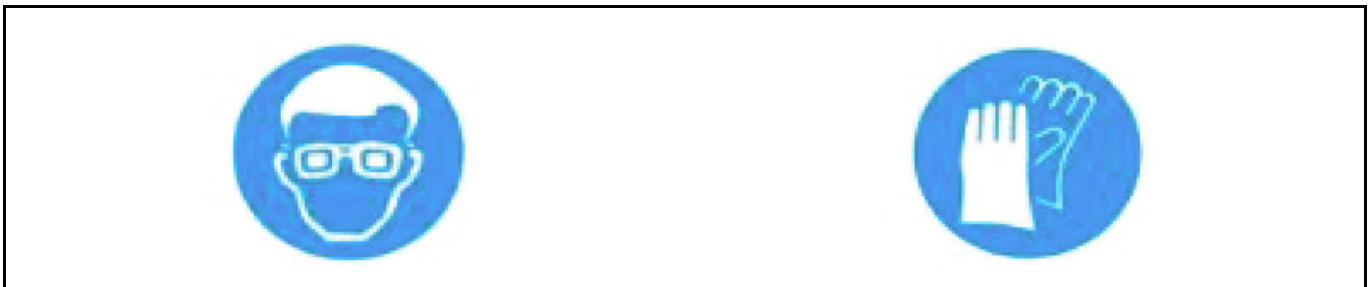

### 2.2.48 Rear Carpet Assembly

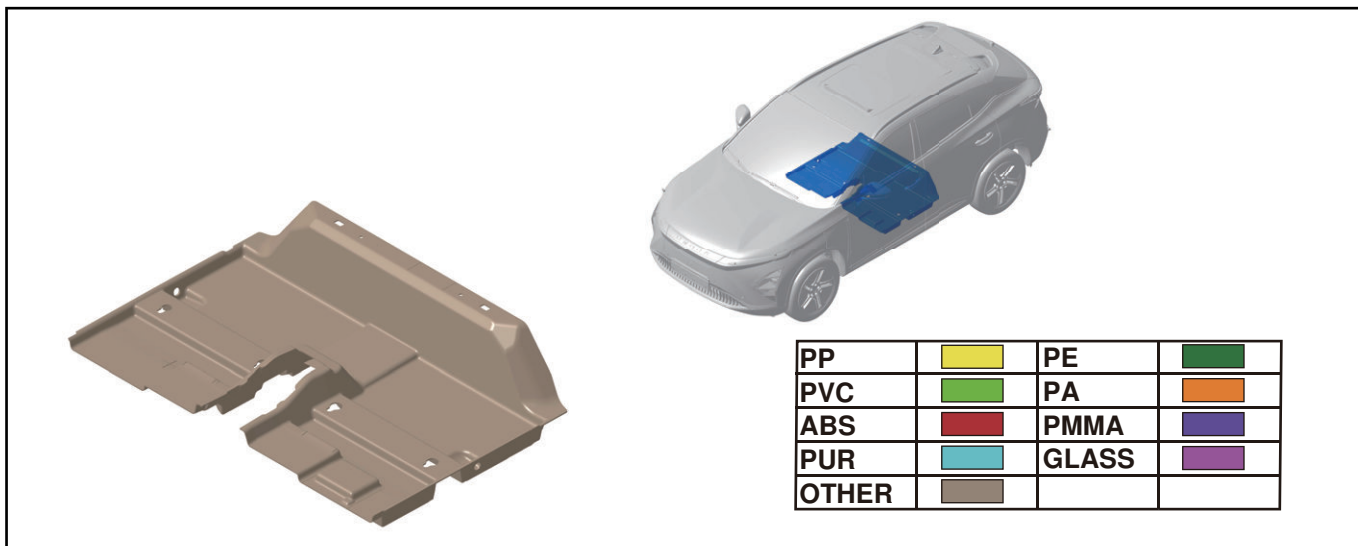

Rear carpet assembly:

Applicable Model	T19C EV
Position Description	Bottom part inside the vehicle
Quantity	1
Weight (Kg)	4
Main Material	PU
Fastener	-
Number of Fasteners	-
Disassembly Tool	-
Disassembly Method	Directly remove
Recycling Pathways	Reuse of rigid polyurethane foam through blending modification
Precautions for Disassembly	Wear protective equipment (goggles, gloves, etc.)

Safety warning sign:



## 2.2.49 Lower Back Door Protector Assembly

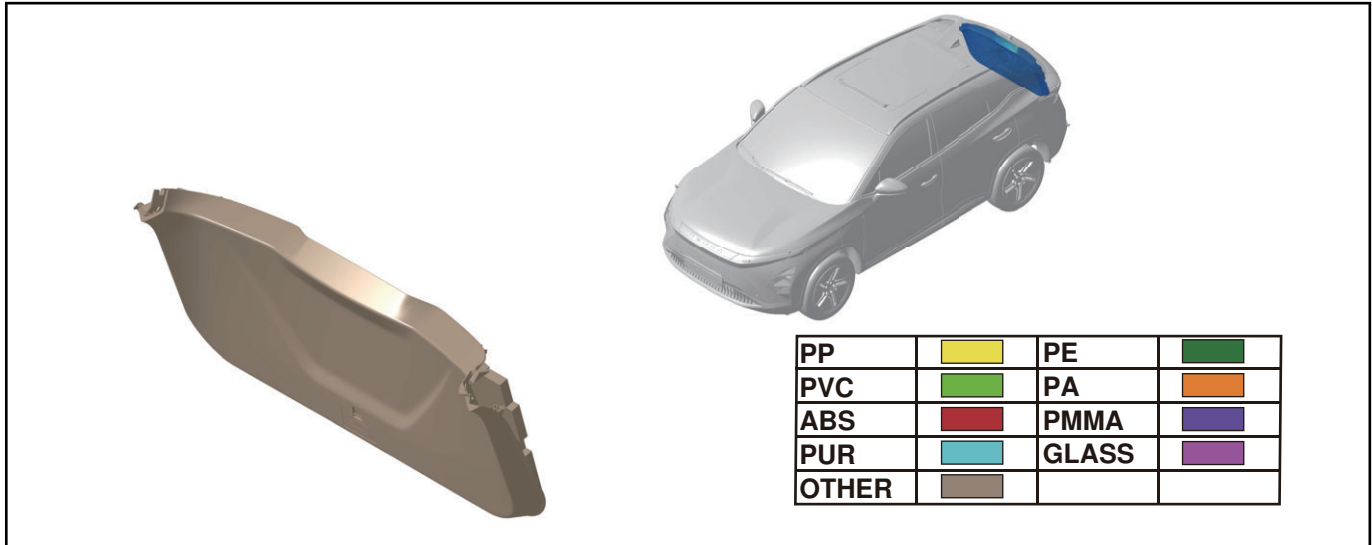

Lower back door protector assembly:

Applicable Model	T19C EV
Position Description	Located on the back door
Quantity	1
Weight (Kg)	1.9
Main Material	API-1020
Fastener	Clip
Number of Fasteners	16
Disassembly Tool	Clip remover
Disassembly Method	Loosen the fasteners for disassembly
Recycling Pathways	Melting and reuse of metal materials
Precautions for Disassembly	Wear protective equipment (goggles, gloves, etc.)

Safety warning sign:



### 2.2.50 Luggage Compartment Storage Box

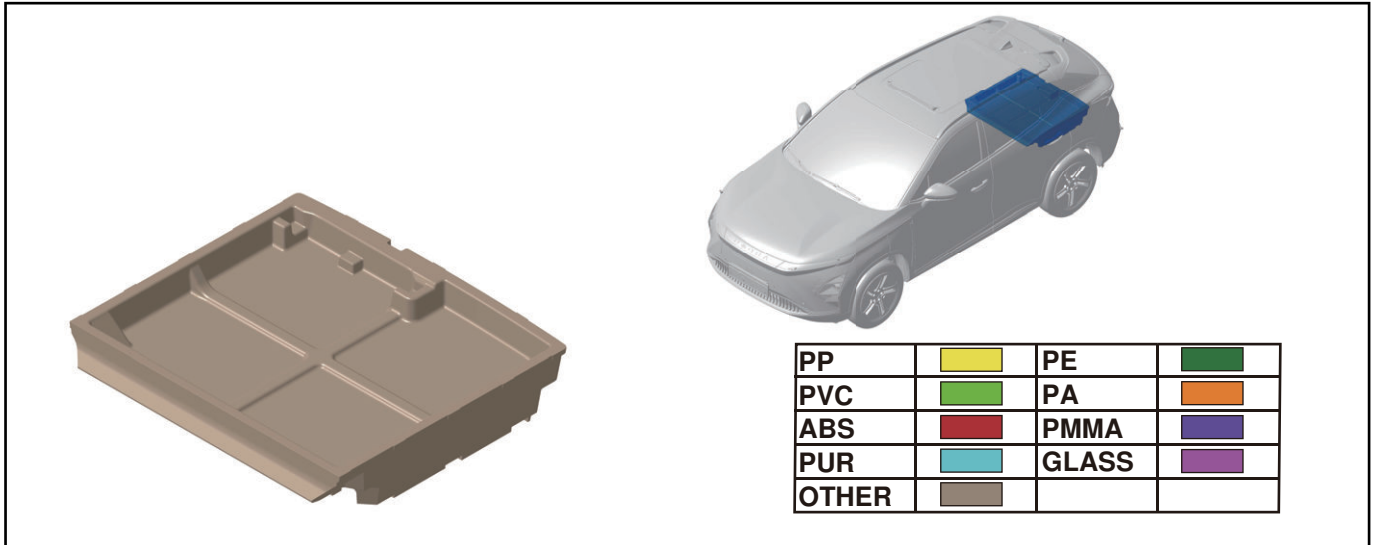

Luggage compartment storage box:

Applicable Model	T19C EV
Position Description	Inside the luggage compartment
Quantity	1
Weight (Kg)	1.1
Main Material	EPP
Fastener	-
Number of Fasteners	-
Disassembly Tool	-
Disassembly Method	Remove directly
Recycling Pathways	Modified recycling of waste plastics
Precautions for Disassembly	Wear protective equipment (goggles, gloves, etc.)

Safety warning sign:



## 2.2.51 Luggage Compartment Carpet Assembly

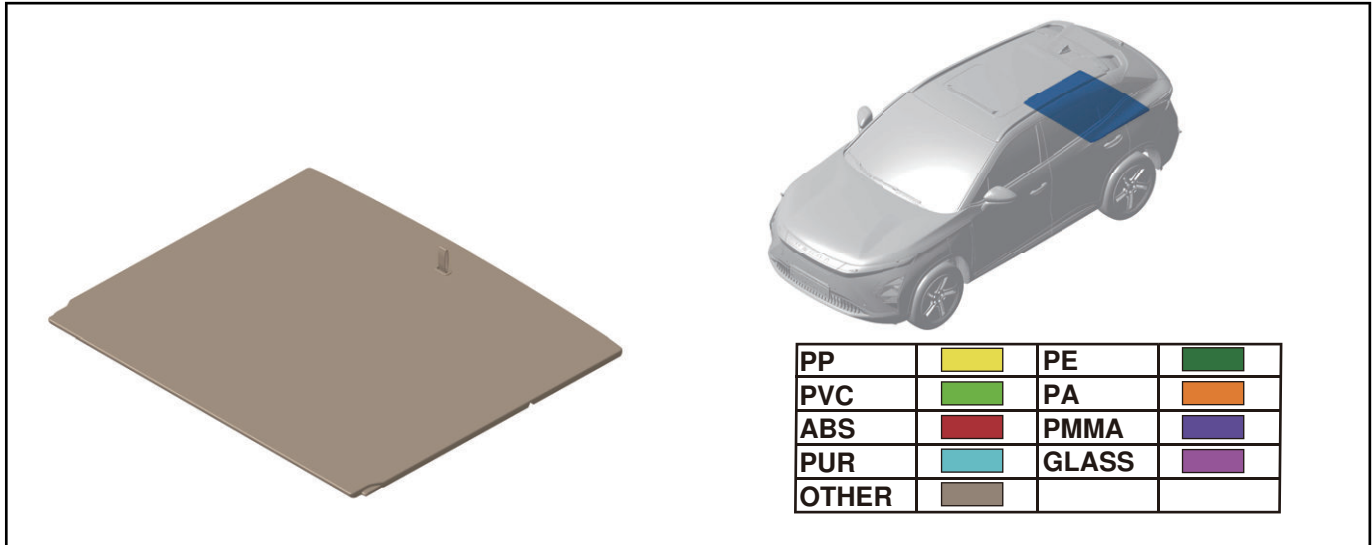

Luggage compartment carpet assembly:

Applicable Model	T19C EV
Position Description	Inside the luggage compartment
Quantity	1
Weight (Kg)	3.8
Main Material	EVA
Fastener	-
Number of Fasteners	-
Disassembly Tool	-
Disassembly Method	Remove directly
Recycling Pathways	Modified recycling of waste plastics
Precautions for Disassembly	Wear protective equipment (goggles, gloves, etc.)

Safety warning sign:



### 2.2.52 Surface Layer of Front Seats

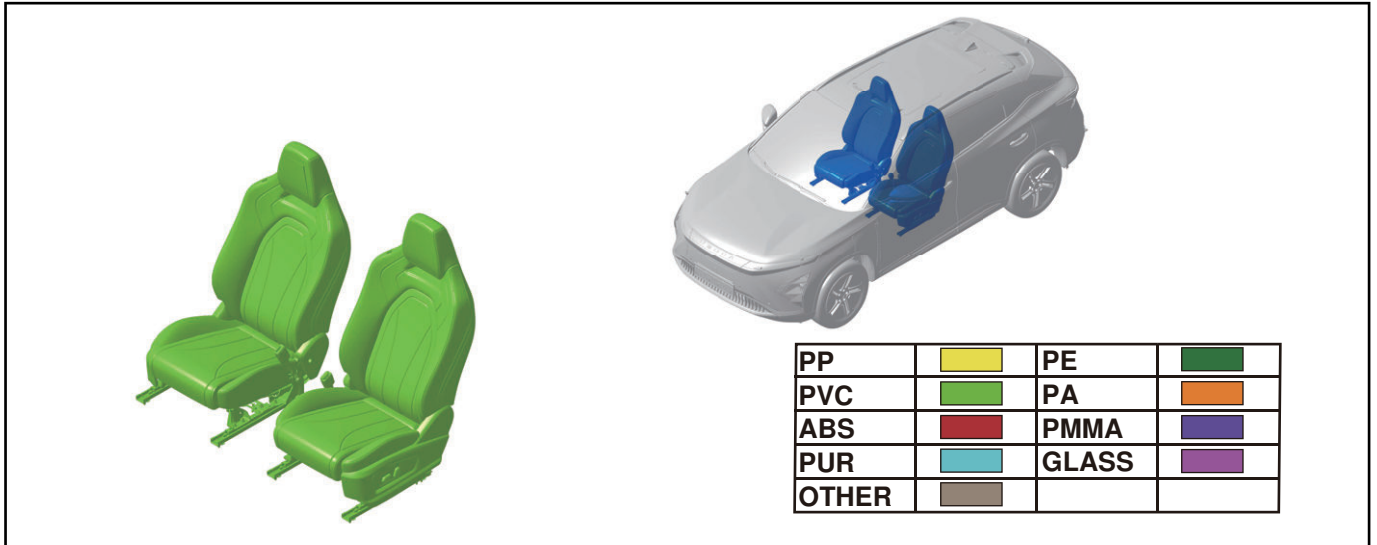

Surface layer of front seats:

Applicable Model	T19C EV
Position Description	On the front seats
Quantity	1
Weight (Kg)	-
Main Material	PVC
Fastener	-
Number of Fasteners	-
Disassembly Tool	Scissors
Disassembly Method	Cut the C-clip and remove the steel wire from the cover
Recycling Pathways	Modified recycling of waste plastics
Precautions for Disassembly	Wear protective equipment (goggles, gloves, etc.)

Safety warning sign:



## 2.2.53 Cushion of Front Seats

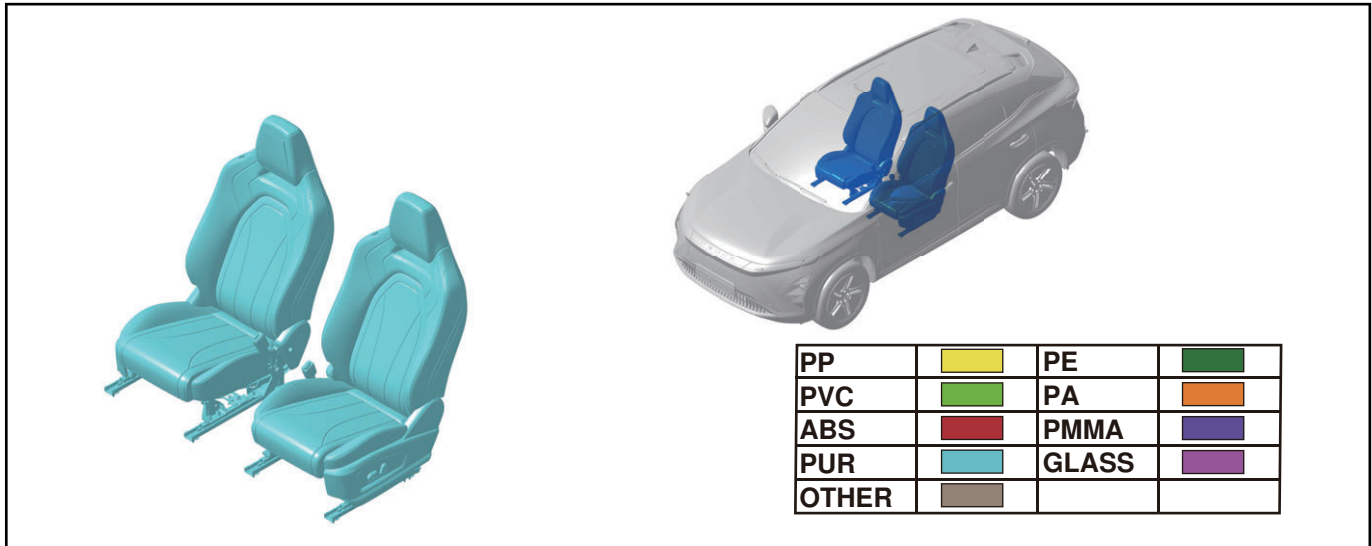

Cushion of front seats:

Applicable Model	T19C EV
Position Description	On the front seats
Quantity	1
Weight (Kg)	-
Main Material	PUR
Fastener	-
Number of Fasteners	-
Disassembly Tool	Scissors
Disassembly Method	Cut the C-clip and remove the steel wire from the cover
Recycling Pathways	Reuse of rigid polyurethane foam through blending modification
Precautions for Disassembly	Wear protective equipment (goggles, gloves, etc.)

Safety warning sign:



### 2.2.54 Surface Layer of Rear Seats

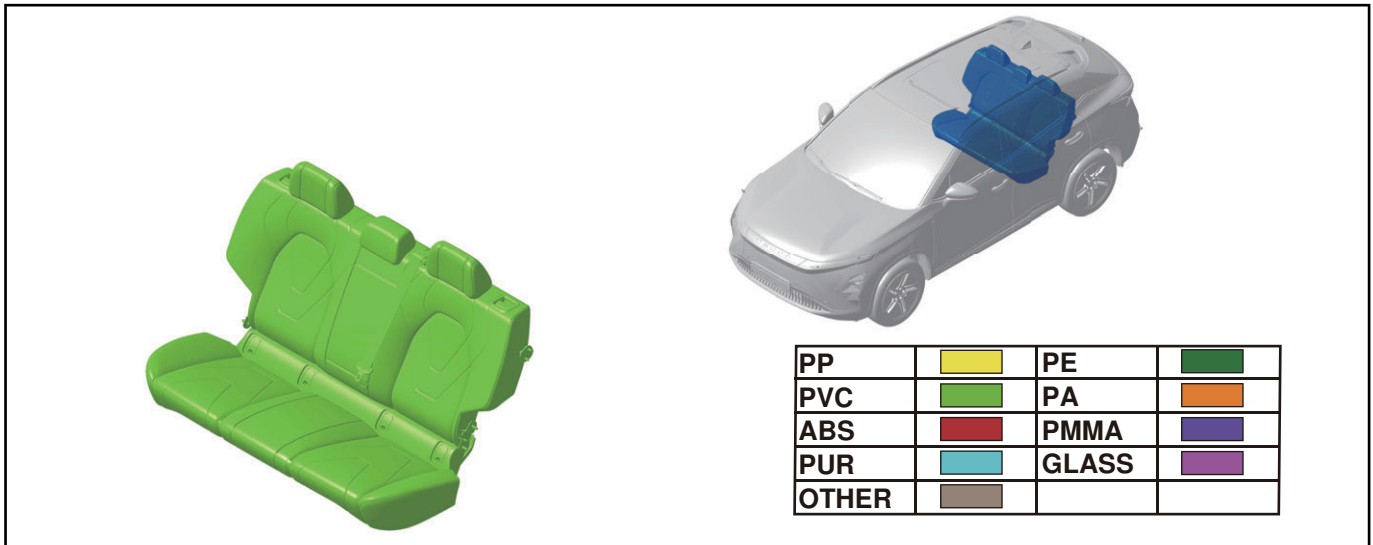

Surface layer of rear seats:

Applicable Model	T19C EV
Position Description	On the rear seats
Quantity	1
Weight (Kg)	-
Main Material	PVC
Fastener	-
Number of Fasteners	-
Disassembly Tool	Scissors
Disassembly Method	Cut the C-clip and remove the steel wire from the cover
Recycling Pathways	Modified recycling of waste plastics
Precautions for Disassembly	Wear protective equipment (goggles, gloves, etc.)

Safety warning sign:



### 2.2.55 Cushion of Rear Seats

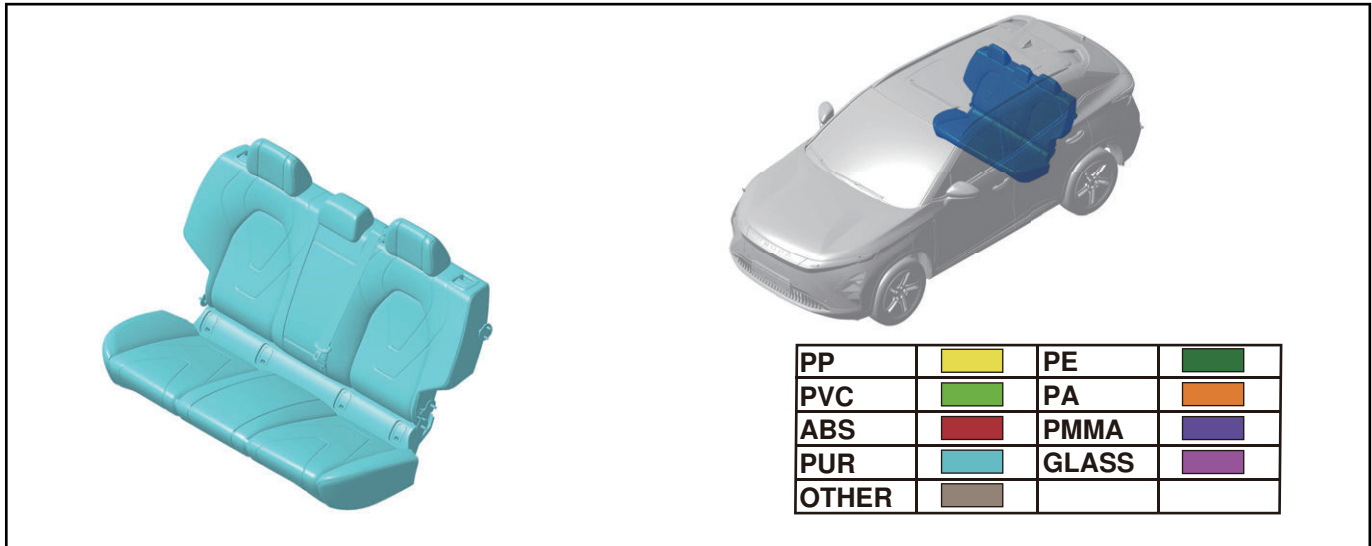

Cushion of rear seats:

Applicable Model	T19C EV
Position Description	On the rear seats
Quantity	1
Weight (Kg)	-
Main Material	PUR
Fastener	-
Number of Fasteners	-
Disassembly Tool	Scissors
Disassembly Method	Cut the C-clip and remove the steel wire from the cover
Recycling Pathways	Reuse of rigid polyurethane foam through blending modification
Precautions for Disassembly	Wear protective equipment (goggles, gloves, etc.)

Safety warning sign:

